



黑偉機械有限公司

HEY-WEL MECHANICAL CO.,LTD.



<http://www.heywel.com>

三葉式魯氏鼓風機

黑偉機械是全國第一家專業製造三葉式魯氏鼓風機，始終抱著勤、誠、信的原則，致力於鼓風機的發展，開發出高壓水冷型鼓風機、沉水式鼓風機、EV高效率鼓風機及逆流式高真空度魯氏泵浦、助力泵浦及直立式鼓風機等系列產品。

特點：

1. 風量壓力真空度範圍大
口徑：32 mm ~ 400 mm (1-1/4"~ 16")
風量：0.3 ~ 278 m³/min (8 ~ 9800 CFM)
壓力：
一段RSS型可達8000 mmAq (0.8 Kg/cm²)
RSW型可達10000 mmAq (1 Kg/cm²)
二段TRS型可達20000 mmAq (2 Kg/cm²)
真空度：
一段可達-500 mmHg
二段可達-600 mmHg
逆流式可達-700 mmHg
2. 排出氣體不含油污。
3. 電腦動平衡校正—低振動低噪音。
4. 風量穩定，壓力變化對風量之影響小。
5. 特殊葉輪設計，高效率省能源。
6. 構造簡單堅固、無故障。
7. 使用一級研磨齒輪，精度高、壽命長、低噪音。
8. 嚴格品質管理，標準化製品。
9. 葉輪採最新之龍門鉋床四軸加工法，一次加工完成，使能有更高之精密度。
10. 每台鼓風機可加裝有活塞環，使效率更高、壽命更長

三葉式和二葉式魯氏鼓風機的差別

傳統二葉式鼓風機同壓力時振幅大，造成震動及噪音、縮短軸承、齒輪及其他傳動元件的壽命。

三葉式鼓風機之優點：

1. 逆壓較小、流速穩定、順暢，故振動較小、噪音較低。
2. 出口壓力變化值較小(如下圖)軸承、齒輪承受力較小、壽命長。
3. 相同轉速時，三葉式振動較小、噪音較低、壽命長。

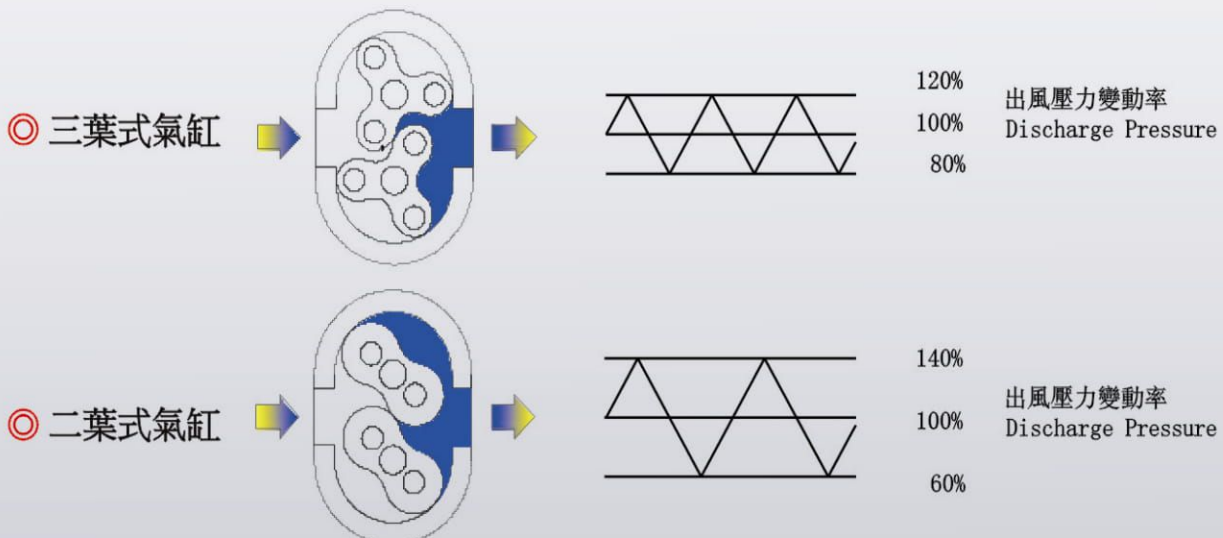

用途：

1. 廢水處理曝氣
2. 燃燒後集塵處理
3. 集塵裝置
4. 染整造紙設備真空脫水
5. 排煙脫硫
6. 環境調節設備
7. 排氣、乾燥
8. 空氣輸送
9. 特殊氣體及粉粒體輸送
10. 水產養殖
11. 電鍍槽液體攪拌
12. 液體攪拌

單位換算表：

壓力 PRESSURE

PRESSURE	mbar	Pa	atm	lbt/in ²	Kgf/cm ²	in Hg	mmAq
1 mbar	1	10 ²	9.869x10 ⁻⁴	1.45x10 ⁻²	1.02x10 ⁻³	2.953x10 ⁻²	10.197
1 Pa	0.01	1	9.87x10 ⁻⁶	1.45x10 ⁻⁴	1.02x10 ⁻⁵	2.953x10 ⁻⁴	0.102
1 atm	1.013x10 ³	1.013x10 ⁵	1	14.7	1.033	29.92	1.033x10 ⁴
1 lbf/in ²	68.95	6.895x10 ²	6.805x10 ⁻²	1	7.03x10 ⁻²	2.036	7.03x10 ²
1 kgf/cm ²	9.807x10 ²	9.807x10 ⁴	0.968	14.22	1	28.96	10 ⁴
1 in Hg	33.86	3.386x10 ³	3.342x10 ⁻²	0.491	3.45x10 ⁻²	1	3.45x10 ²
1 mmAq	9.807x10 ⁻²	9.807	9.667x10 ⁻⁵	1.42x10 ⁻³	10 ⁻⁴	2.896x10 ⁻³	1

壓力常用換算公式

Pressure Conversion Formula

- 1 Pa = 0.102 mmAq
- 1 mbar = 10.197 mmAq
- 1 mmHg = 13.6 mmAq
- 1 psi = 703 mmAq
- 1 Torr = 133.3 Pa
- 1 Torr = 1.333 mbar

風量 CAPACITY

CAPACITY	m ³ /min	m ³ /h	ℓ/min	ft ³ /min(cfm)
1 m ³ /min	1	60	1000	35.31
1 m ³ /h	0.017	1	16.67	0.589
1 ℓ/min	0.001	0.06	1	0.035
1 ft ³ /min(cfm)	0.028	1.699	28.32	1

功率 POWER

POWER	kg-m/sec	kw	HP	PS
1 kg-m/sec	1	0.01	0.013	0.013
1 kw	101.97	1	1.341	1.360
1 HP	76.038	0.746	1	1.014
1 PS	75	0.736	0.986	1

訂製資料：

1. 用途及使用狀況

說明用途、使用場所及運轉的情形，例如連續運轉或間歇性運轉。

2. 風量

說明要求的風量是在標準狀態（一大氣壓、20°C、相對濕度65%）或基準狀態，除非特別說明，一般均指入口狀態而非出口狀態。

3. 壓力

需註明使用壓力是否穩定在一特定的壓力值或壓力隨時在改變。假如壓力有變化，請說明壓力改變和風量的相對關係。如壓力下降則風量增大，反之則風量減少。並訂出其變化的範圍。所訂定的壓力是指出口的靜壓或是出入口的壓差均須標明，還有入口壓力是否在一大氣壓下，如非一大氣壓請註明其出入口的壓力。

4. 輸送氣體的種類及其比重

請標明下列各項：

- a. 氣體種類及其成分
- b. 其他物質的成分及其大小
- c. 比重
- d. 化學性質
- e. 建議使用材質
- f. 是否有爆炸性或毒性

如無註明上列事項，將以一般空氣處理之。

5. 氣體溫度

黑偉魯氏鼓風機的標準規格品是用來輸送入口溫度為常溫的氣體，如入口使用溫度高於常溫，請告知公司，以便作特殊設計以適用於高溫狀態。

6. 原動機

如使用馬達帶動，請告知電源之電壓、頻率、單相或三相等。

RSS本體結構圖

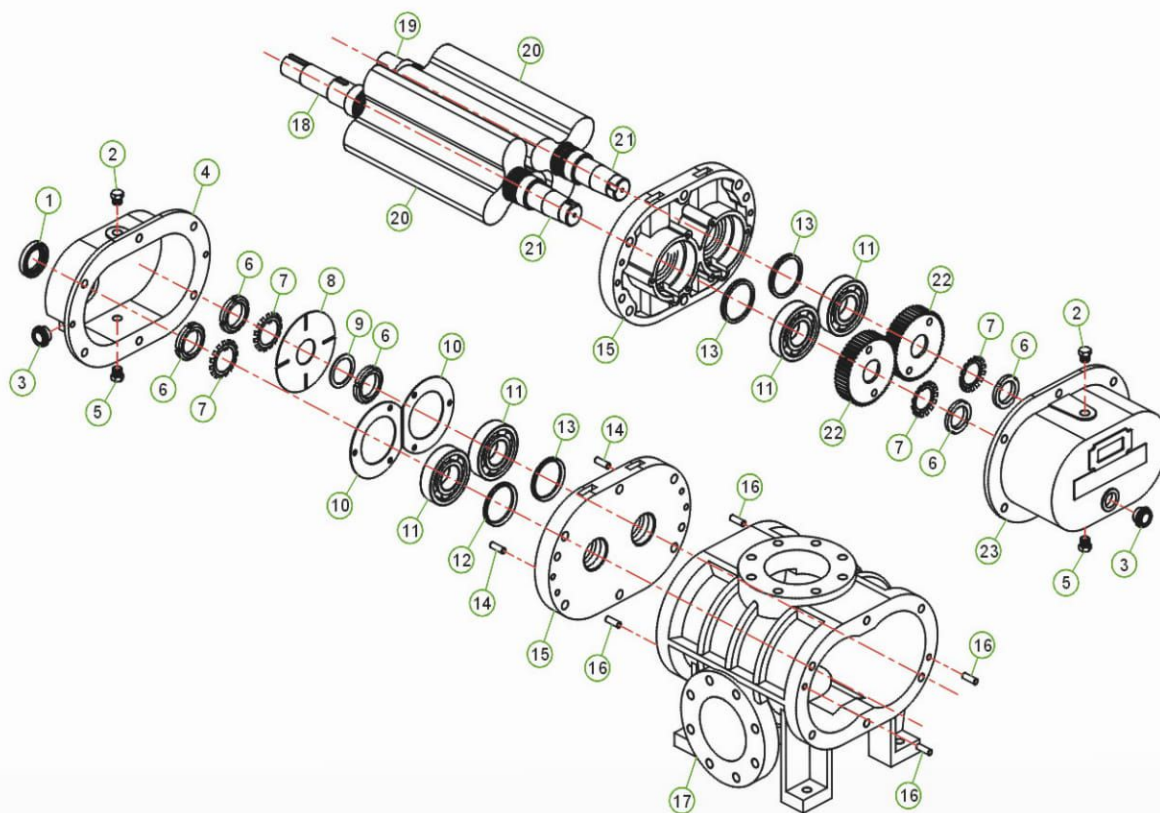

序號 NO.	名稱 NAME	材質 MATERIAL	數量 QTY	序號 NO.	名稱 NAME	材質 MATERIAL	數量 QTY
1	TC油封 TC Oil seal	NBR	1	16	定位銷 Positioning pins	S45C	4
2	加油栓塞 Lubricant plug	ABS	2	17	鼓風機本體 Blower casing	FC250	1
3	潤滑油鏡 Oil sight window	Glass	2	18	傳動軸 Drive shaft	SCM440	1
4	油箱 Oil reservoir	FC250	1	19	被動軸 Driven shaft	SCM440	1
5	洩油栓塞 Purge plug	S45C	2	20	葉輪 Rotors	FC250	2
6	止動螺帽 Locking nuts	S45C	5	21	齒輪軸 Gear Shaft	SCM440	2
7	太陽墊圈 Lock washer	S45C	4	22	齒輪 Timing gears	SNM220	2
8	甩油片 Oil thrower	SS400	1	23	齒輪箱 Oil reservoir	FC250	1
9	墊片 Oil thrower washer	SS400	1				
10	軸承固定片 Bearing fixtures	SS400	2				
11	軸承 Bearings	SUJ2	4				
12	TC油封 TC Oil seal	NBR	1				
13	V型油封 V-ring	Viton	3				
14	定位銷 Positioning pins	S45C	2				
15	軸承座 Bearing case	FC250	2				

RSS本體尺寸圖

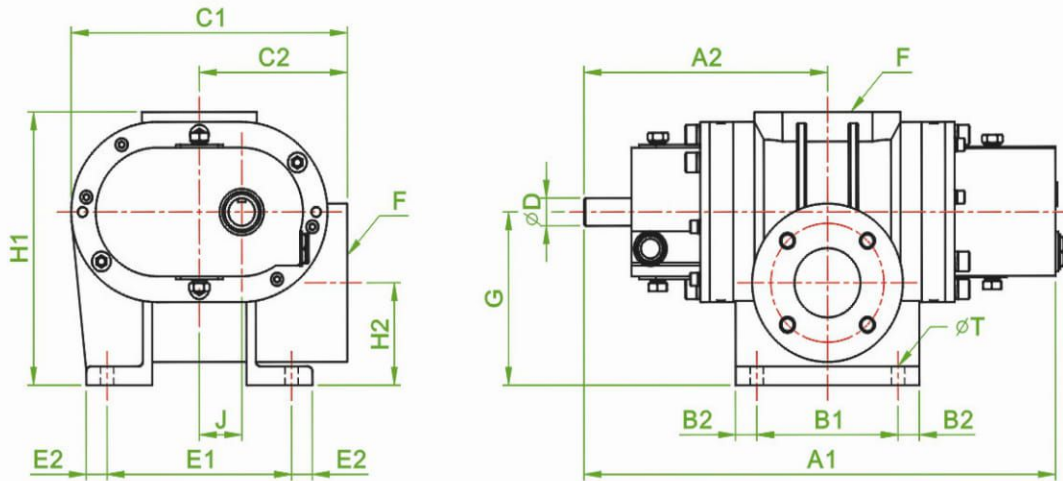

Model	A1	A2	B1	B2	C1	C2	ϕD	ϕT	E1	E2	ϕF	G	H1	H2	J	Wt.(kg)
RSS-40	421	219	80	15	276	140	28	14	196	22	JIS 5K 1½" / 10K 2"	180	285	104	45	55
RSS-50	501	259	150	22.5	276	140	28	14	196	22	JIS 10K 2"	191	292	104	45	70
RSS-65	561	289	196	27	288	152	28	14	196	27	JIS 10K 2.5"	194	295	104	45	72
RSS-80	640	343	196	22	358	180	38	14	196	22	JIS 10K 3"	212	341	107	60	136
RSS-100	740	393	282	24	358	180	38	14	232	29	JIS 10K 4"	217	352	112	60	148
RSS-125A	770	400	210	20	483	250	48	19	346	27	JIS 10K 5"	262	430	135	80	248
RSS-125	890	460	310	30	483	250	48	19	355	22.5	JIS 10K 5"	262	430	163	80	274
RSS-150	1000	515	428	26	483	250	48	19	355	22.5	JIS 10K 6"	289	453	163	80	308
RSS-200A	993	495	239	45.5	700	360	65	23	555	42.5	JIS 10K 8"	402	630	198	120	640
RSS-200	1093	545	400	38	690	350	65	23	550	35	JIS 10K 8"	402	630	198	120	732
RSS-250	1243	620	520	25	700	360	65	23	550	35	JIS 10K 10"	435	660	218	120	929
RSS-300A	1479	756	680	45	700	360	75	23	540	40	JIS 10K 12"	435	675	255	120	1071
RSS-300	1306	699	420	55	1010	510	95	33	780	35	JIS 10K 12"	550	880	300	180	1700
RSS-350	1626	859	740	55	1010	510	95	33	780	35	JIS 10K 14"	550	880	300	180	2250
RSS-400	1766	929	880	55	1010	510	95	33	780	35	JIS 10K 16"	550	880	300	180	2500

▽ RSS-32

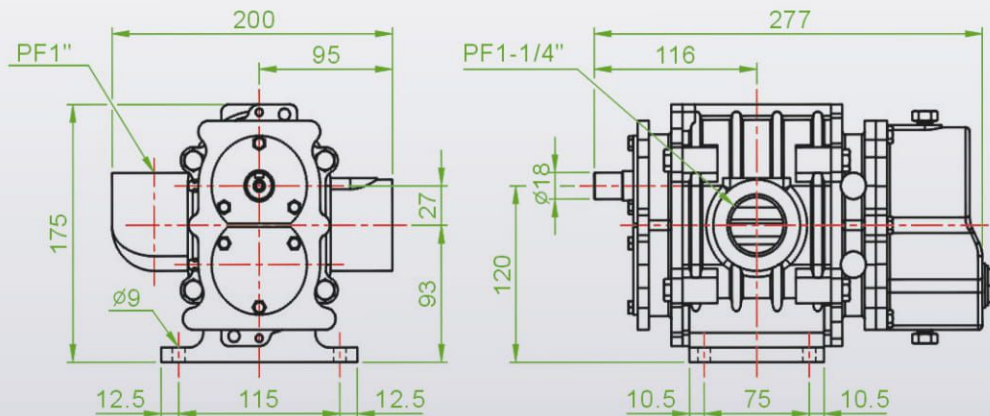

Model	A1	A2	B1	B2	C1	C2	ϕD	ϕT	E1	E2	ϕF	G	H1	H2	J	Wt.(kg)
RSS-32	277	116	75	10.5	200	95	18	9	115	12.5	1"PF / 1¼"PF	120	175	93	27	17

RSS外型尺寸圖

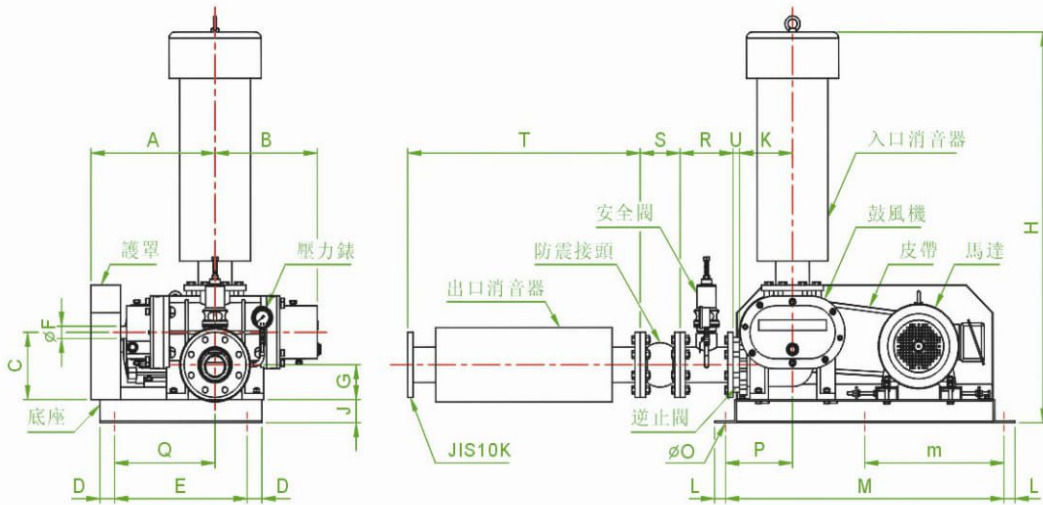

※重量不含馬達

Model	A	B	C	D	E	φF	G	H	J	K	L	M	m	φO	P	Q	R	U	S	T	Wt.(kg)
RSS-40	235	202	180	20	350	28	104	731	46	140	50	500	-	14	98	255	150	20	105	589	85
RSS-50	274	242	191	50	350	28	104	933	75	140	37.5	795	-	12.7	208	209	150	20	105	589	122
RSS-65	303	272	194	50	350	28	104	936	75	152	37.5	795	-	12.7	208	238	150	24	115	589	132
RSS-80	371	297	212	50	450	38	107	1251	75	180	37.5	945	-	12.7	228	291	180	24	136	789	233
RSS-100	421	347	217	50	450	38	112	1262	75	180	37.5	945	-	12.7	228	341	180	22	136	789	247
RSS-125A	435	371	262	25	550	48	135	1851	100	250	100	900	-	19	133	240	250	24	174	1260	408
RSS-125	495	431	262	25	550	48	163	1851	100	250	100	900	-	19	138	300	250	24	174	1260	434
RSS-150	536	486	289	25	550	48	163	1874	100	250	100	900	-	19	138	341	250	26	180	1260	485
RSS-200A	560	498	402	32.5	935	65	198	2263	125	360	100	1300	650	20	313	352	250	27	205	1640	990
RSS-200	610	548	402	32.5	935	65	198	2263	125	350	100	1300	650	20	313	403	250	27	205	1640	1080
RSS-250	685	623	435	32.5	935	65	218	2500	125	360	100	1300	650	20	313	478	250	28	240	1760	1350
RSS-300A	800	723	435	37.5	925	75	255	2682	150	360	235	1530	765	24	273	523	300	32	260	1750	1660
RSS-300	780	607	550	45	1010	95	300	3097	250	510	235	2000	1000	33	325	400	300	32	260	1850	2500
RSS-350	940	767	550	45	1110	95	300	3367	250	510	235	2000	1000	33	325	560	350	35	265	2500	3380
RSS-400	1020	837	550	45	1110	95	300	3663	250	510	235	2000	1000	33	325	670	350	40	265	2700	3850

▽ RSS-32

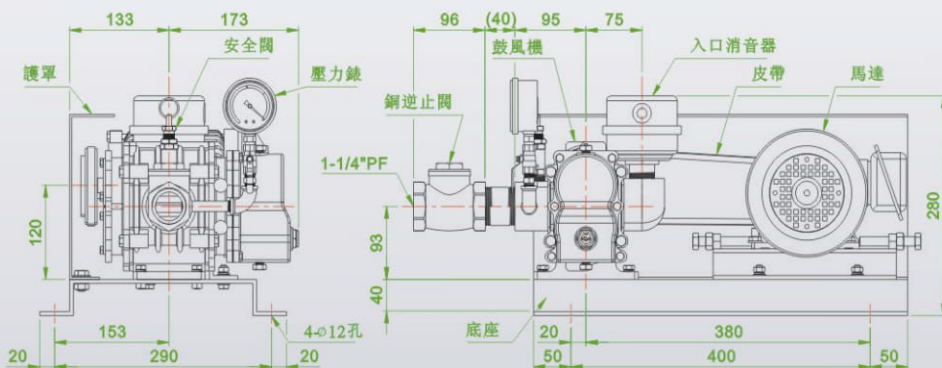

Model	A	B	C	D	E	φF	G	H	J	K	L	M	m	φO	P	Q	R	U	S	T	Wt.(kg)
RSS-32	133	173	120	20	290	18	93	280	40	95	50	400	-	12	20	153	40	96	-	-	28

RSS性能表

註：入口流量 Qs=m³/min

機型 Model	轉速 RPM	Type RSS-300 performance															
		1000mmAq		2000mmAq		3000mmAq		4000mmAq		5000mmAq		6000mmAq		7000mmAq		8000mmAq	
		Qs	kw	Qs	kw	Qs	kw	Qs	kw	Qs	kw	Qs	kw	Qs	kw	Qs	kw
RSS-300	600	72.16	16.96	69.33	30.43	67.10	43.80	64.99	57.52	63.17	70.07	61.59	84.13	60.01	95.88	58.42	109.07
	700	85.55	19.78	82.72	35.49	80.49	51.09	78.38	67.09	76.56	81.74	74.98	98.11	73.40	111.82	71.81	127.38
	800	98.94	22.60	96.11	40.56	93.88	58.38	91.77	76.69	89.95	94.00	88.37	112.10	86.79	127.76	85.20	144.79
	900	112.33	25.42	109.50	45.62	107.27	65.65	105.16	86.22	103.34	105.50	101.76	126.08	100.18	143.70	98.59	163.73
	1000	125.72	28.24	122.89	50.69	120.66	72.93	118.55	95.82	116.73	116.70	115.15	140.12	113.57	159.69	111.98	180.87
	1100	139.05	31.06	136.28	55.76	134.05	80.22	131.94	105.36	130.12	128.37	128.54	153.87	126.95	175.63	125.37	198.18
	1200	152.44	33.89	149.67	60.83	147.44	87.51	145.32	114.96	143.51	140.04	141.93	168.08	140.34	191.57	138.76	215.37
	1300	165.82	36.71	163.06	65.89	160.83	94.79	158.71	124.53	156.90	151.70	155.32	182.08	153.73	207.51	152.15	232.61
1400	179.20	39.53	176.45	70.96	174.22	102.08	172.10	134.11	170.29	163.36	168.71	196.07	167.12	223.46	165.54	250.12	

機型 Model	轉速 RPM	Type RSS-350 performance															
		1000mmAq		2000mmAq		3000mmAq		4000mmAq		5000mmAq		6000mmAq		7000mmAq		8000mmAq	
		Qs	kw	Qs	kw	Qs	kw	Qs	kw	Qs	kw	Qs	kw	Qs	kw	Qs	kw
RSS-350	600	113.86	26.45	109.57	47.50	106.22	67.72	103.06	89.11	100.36	109.17	98.03	130.69	95.70	149.35	93.38	173.50
	700	134.90	30.88	130.61	55.39	127.26	79.11	124.10	104.02	121.40	127.51	119.07	152.57	116.74	174.40	114.41	202.64
	800	155.94	35.31	151.65	63.30	148.30	91.17	145.14	118.96	142.44	145.75	140.11	174.47	137.78	199.45	135.45	232.32
	900	176.97	39.74	172.69	73.20	169.34	102.05	166.18	133.82	163.48	164.10	161.15	196.35	158.82	224.49	156.49	260.83
	1000	198.01	44.17	193.73	79.10	190.38	114.04	187.22	148.76	184.52	182.44	182.19	218.28	179.86	249.62	177.53	289.96
	1100	218.96	48.60	214.77	87.00	211.42	125.49	208.26	163.66	205.56	200.78	203.23	239.98	200.90	274.67	198.57	318.90
	1200	240.00	53.00	235.81	94.90	232.46	136.95	229.29	178.60	226.59	219.14	224.27	262.05	221.94	299.72	219.61	347.60
	1300	261.02	57.40	256.85	102.80	253.50	148.39	250.33	193.47	247.63	237.44	245.31	283.95	242.98	324.77	240.65	376.30
1400	282.05	61.80	277.89	110.70	274.54	159.85	271.37	208.40	268.67	255.77	266.35	305.84	264.02	349.83	261.69	405.00	

機型 Model	轉速 RPM	Type RSS-400 performance															
		1000mmAq		2000mmAq		3000mmAq		4000mmAq		5000mmAq		6000mmAq		7000mmAq		8000mmAq	
		Qs	kw	Qs	kw	Qs	kw	Qs	kw	Qs	kw	Qs	kw	Qs	kw	Qs	kw
RSS-400	600	132.68	30.77	127.69	55.24	123.78	79.50	120.09	104.41	116.95	127.18	114.23	152.71	111.52	174.03	109.13	202.14
	700	157.19	35.90	152.20	64.44	148.30	92.76	144.61	121.80	141.46	148.40	138.75	178.12	136.04	203.00	133.64	235.85
	800	181.71	41.03	176.72	73.65	172.82	106.00	169.13	139.25	165.98	169.51	163.27	203.54	160.56	231.97	158.16	269.45
	900	206.23	46.16	201.24	86.09	197.33	119.22	193.64	156.58	190.50	190.72	187.79	228.95	185.07	260.94	182.68	303.15
	1000	230.75	51.28	225.76	92.07	221.85	132.46	218.16	174.03	215.02	211.94	212.30	254.48	209.59	290.01	207.20	336.86
	1100	255.15	56.41	250.27	101.27	246.37	145.71	242.68	191.37	239.53	233.15	236.82	279.46	234.11	318.98	231.72	370.57
	1200	279.67	61.55	274.79	110.49	270.88	158.95	267.20	208.81	264.05	254.37	261.34	305.31	258.63	347.95	256.24	404.28

RSS性能曲線圖

RSS-32

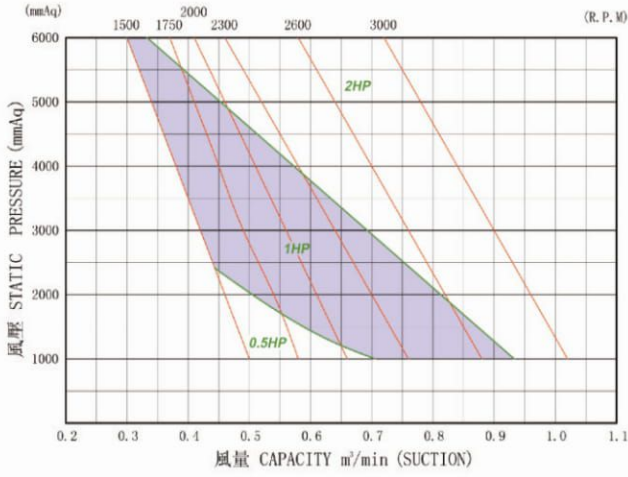

RSS-40

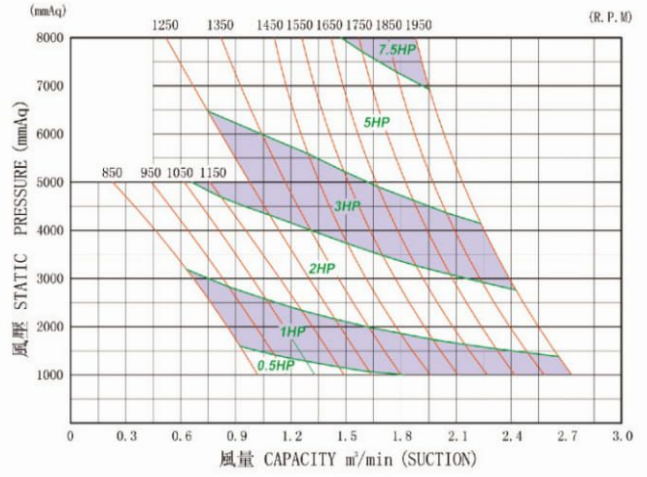

RSS-50

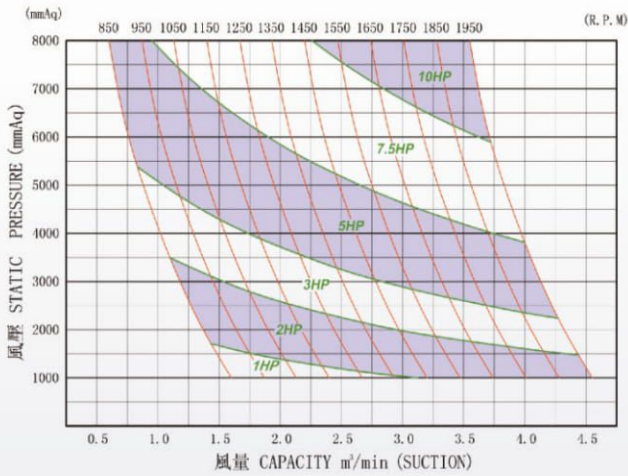

RSS-65

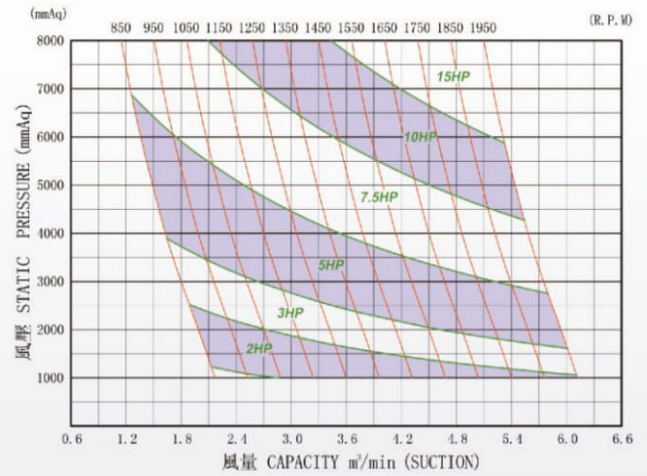

RSS-80

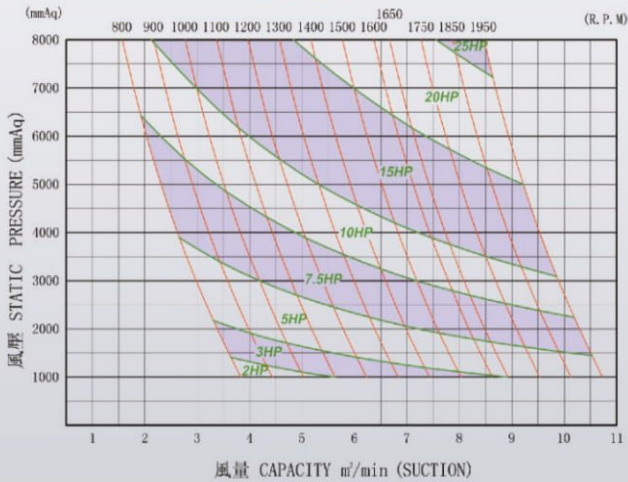

RSS-100

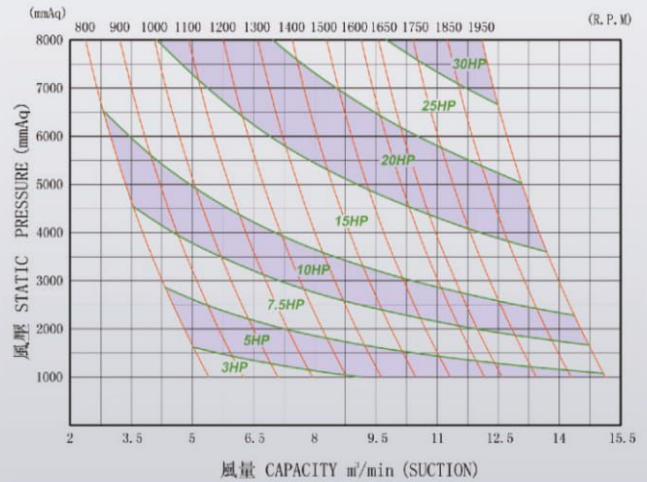

RSS性能曲線圖

RSS-125A

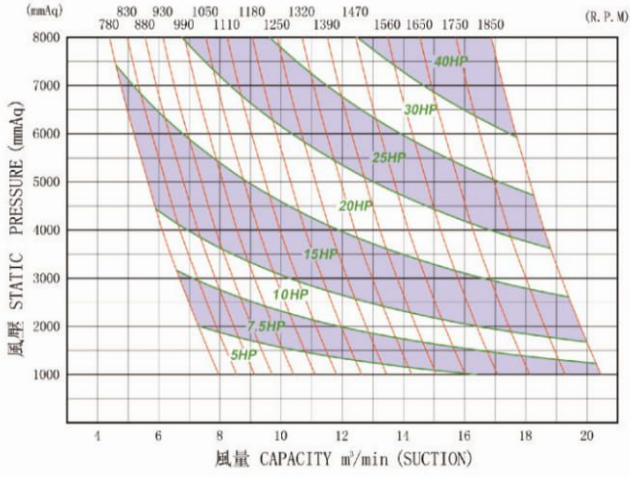

RSS-125

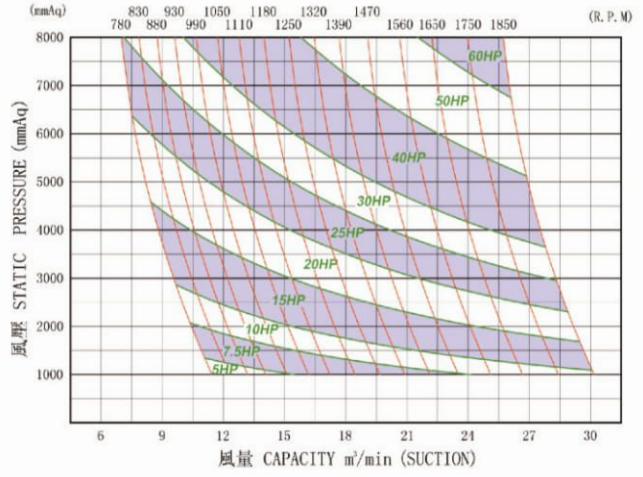

RSS-150

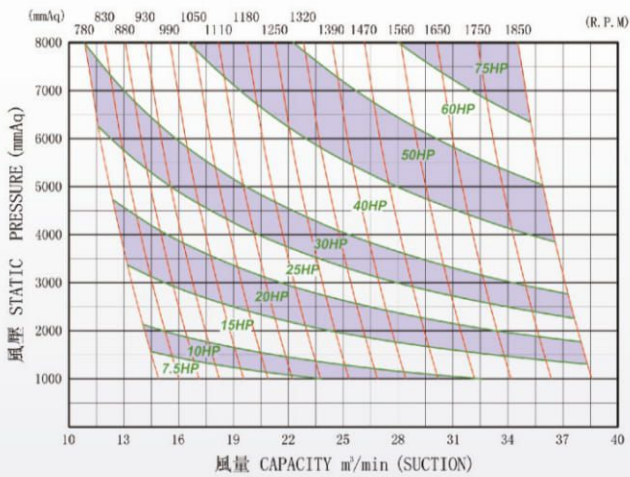

RSS-200A

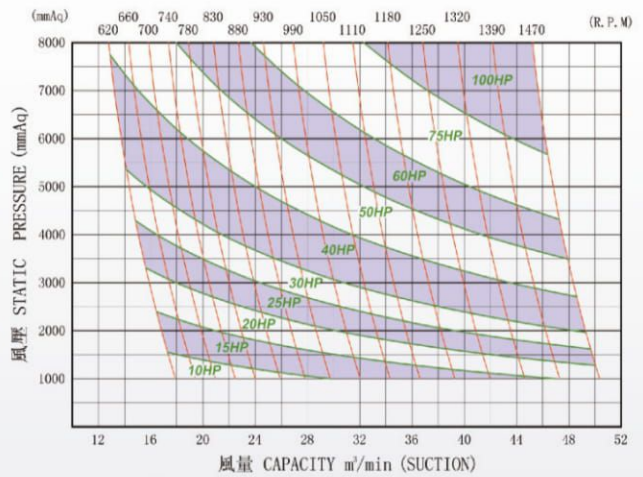

RSS-200

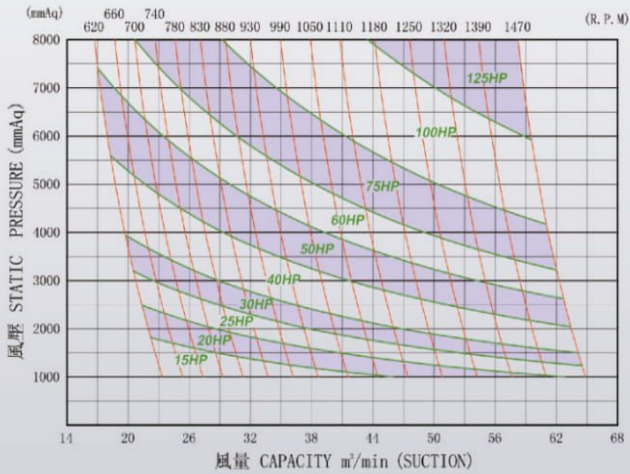

RSS-250

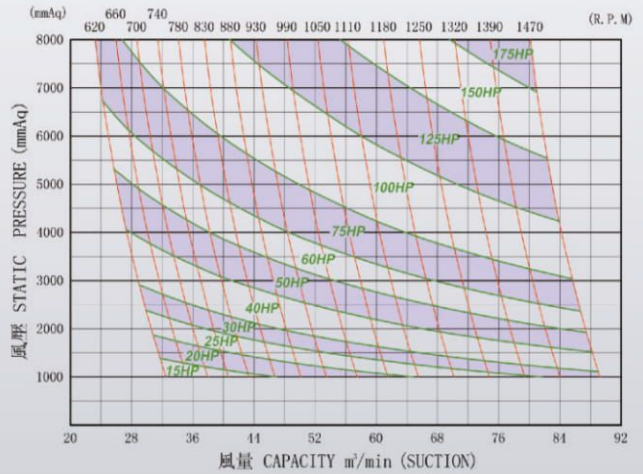

RSS性能曲線圖

RSS-300A

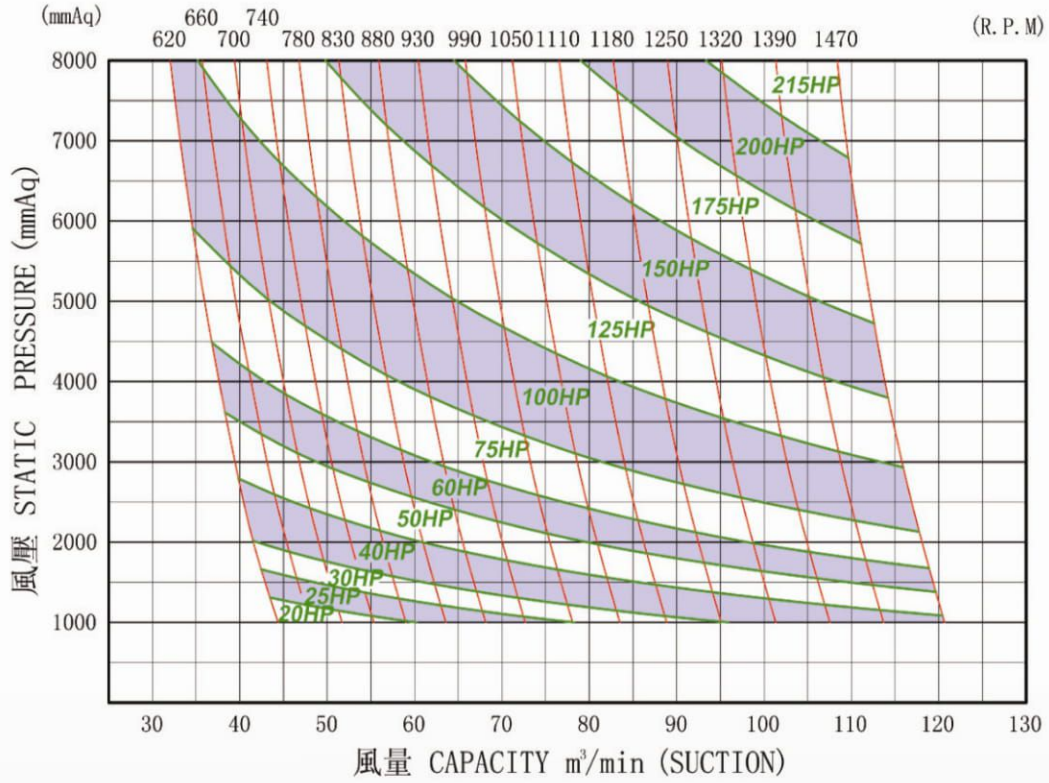

RSS-300

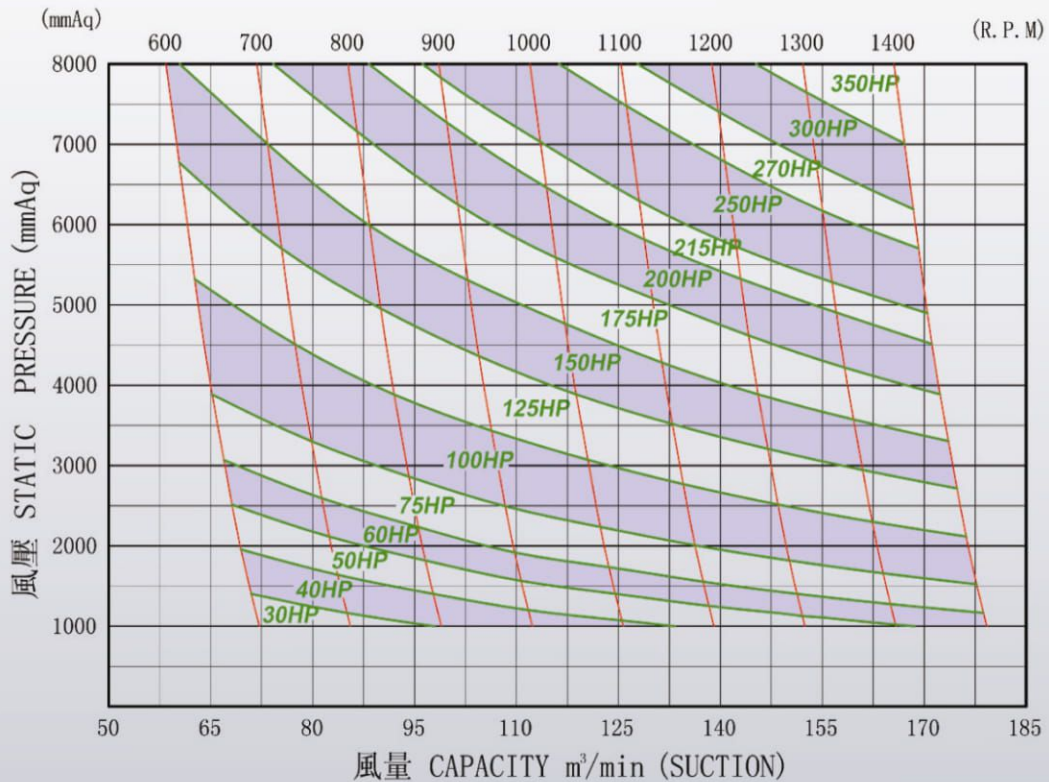

RSS性能曲線圖

RSS-350

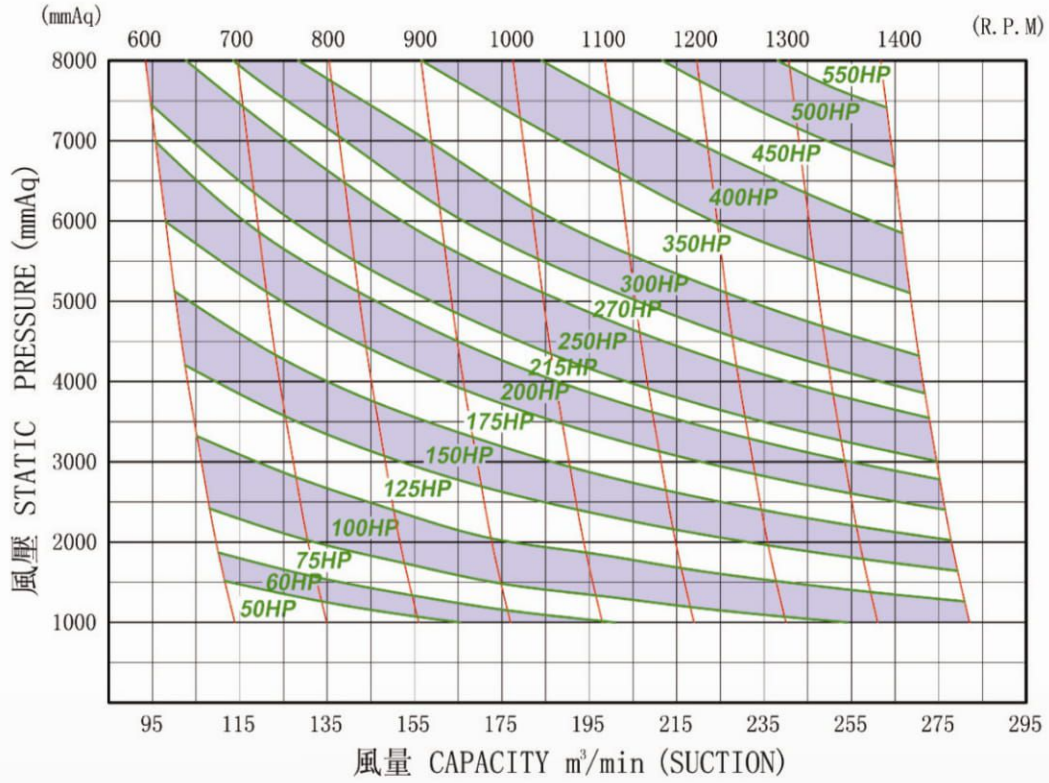

RSS-400

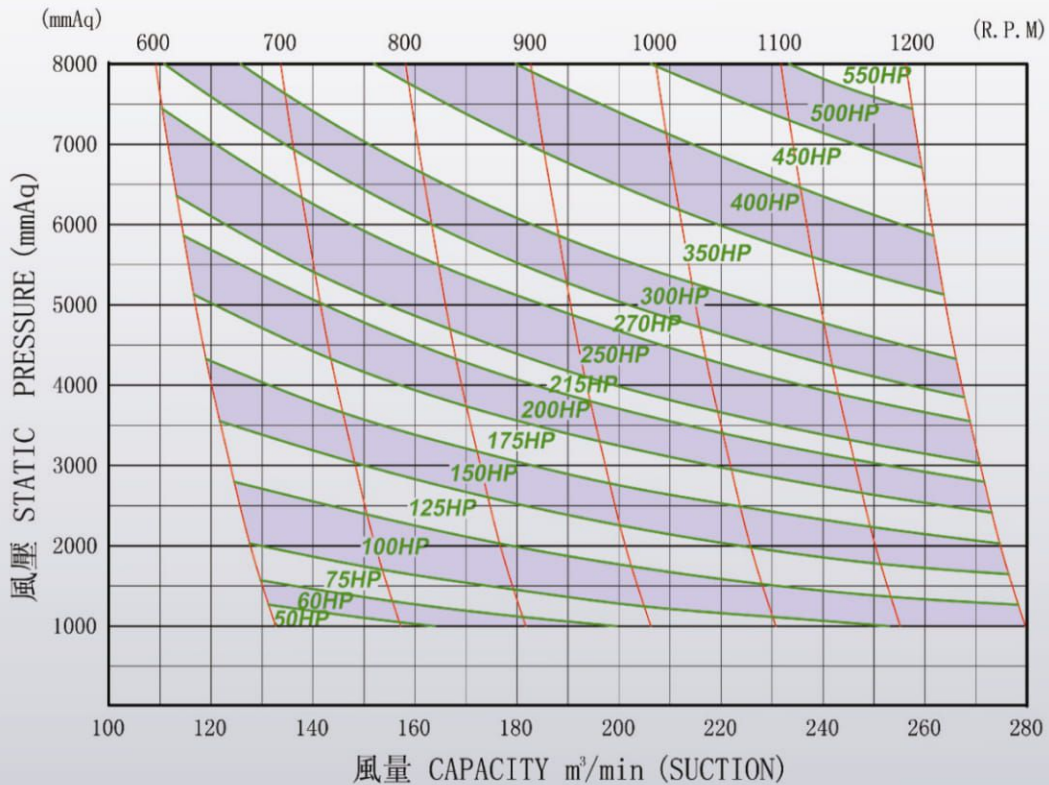

RSV外型尺寸圖

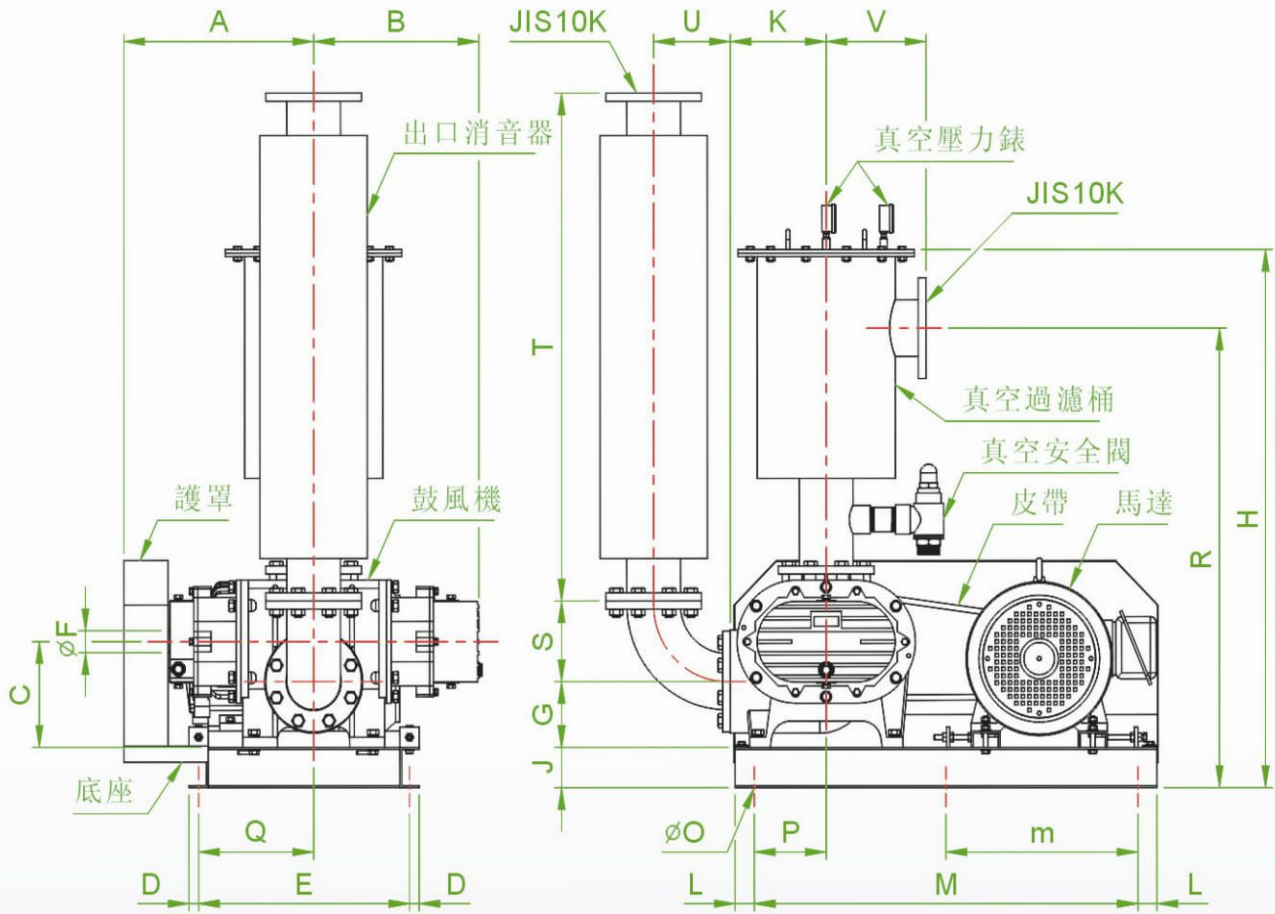

Model	A	B	C	D	E	φF	G	H	J	K	L	M	m	φO	P	Q	R	S	T	U	V
RSV-40	235	202	180	20	350	28	104	988	46	140	50	500	-	14	98	255	790	82	589	121	202
RSV-50	274	242	191	50	350	28	104	1024	75	140	37.5	795	-	12.7	208	209	826	82	589	121	202
RSV-65	303	272	194	50	350	28	104	1027	75	152	37.5	795	-	12.7	208	238	829	105	589	105	202
RSV-80	371	297	212	50	450	38	107	1293	75	180	37.5	945	-	12.7	228	291	1029	121	789	121	202
RSV-100	421	347	217	50	450	38	112	1304	75	180	37.5	945	-	12.7	228	341	1040	162	789	162	202
RSV-125A	435	371	262	25	550	48	135	1335	100	250	100	900	-	19	133	240	1140	200	1260	200	260
RSV-125	495	431	262	25	550	48	163	1335	100	250	100	900	-	19	138	300	1140	200	1260	200	260
RSV-150	536	486	289	25	550	48	163	1478	100	250	100	900	-	19	138	341	1243	239	1260	239	260
RSV-200A	560	498	402	32.5	935	65	198	1830	125	360	100	1300	650	20	313	352	1525	315	1640	315	310
RSV-200	610	548	402	32.5	935	65	198	1830	125	350	100	1300	650	20	313	403	1525	315	1640	315	310
RSV-250	685	623	435	32.5	935	65	218	1985	125	360	100	1300	650	20	313	478	1685	391	1760	391	310
RSV-300A	800	723	435	37.5	925	75	255	2175	150	360	235	1530	765	24	273	523	1825	465	1750	465	405
RSV-300	780	607	550	45	1010	95	300	2480	250	510	235	2000	1000	33	325	400	2130	465	1850	465	405
RSV-350	940	767	550	45	1110	95	300	2680	250	510	235	2000	1000	33	325	560	2280	542	2500	542	455
RSV-400	1020	837	550	45	1110	95	300	2880	250	510	235	2000	1000	33	325	670	2380	620	2700	620	455

RSV性能表

註：入口流量 Qs=m³/min

機型 Model	轉速 RPM	Type RSV-40 performance											
		-1000mmAq		-2000mmAq		-3000mmAq		-4000mmAq		-5000mmAq		-6000mmAq	
		Qs	kw	Qs	kw	Qs	kw	Qs	kw	Qs	kw	Qs	kw
RSV-40	1050	1.32	0.29	1.14	0.58	0.93	0.87	0.67	1.16				
	1150	1.48	0.32	1.30	0.64	1.08	0.95	0.81	1.27				
	1250	1.63	0.35	1.45	0.69	1.24	1.04	1.00	1.38				
	1350	1.79	0.37	1.60	0.75	1.40	1.12	1.17	1.49				
	1450	1.95	0.40	1.75	0.80	1.55	1.20	1.33	1.60	1.08	2.00	0.80	2.40
	1550	2.10	0.43	1.91	0.86	1.71	1.29	1.49	1.71	1.24	2.14	0.95	2.57
	1650	2.26	0.46	2.06	0.91	1.86	1.37	1.64	1.82	1.39	2.28	1.11	2.74
	1750	2.41	0.48	2.22	0.97	2.02	1.45	1.80	1.93	1.55	2.42	1.26	2.90
	1850	2.57	0.51	2.37	1.02	2.17	1.53	1.95	2.05	1.70	2.56	1.42	3.07
1950	2.72	0.54	2.53	1.08	2.33	1.62	2.11	2.16	1.86	2.70	1.57	3.23	

機型 Model	轉速 RPM	Type RSV-50 performance											
		-1000mmAq		-2000mmAq		-3000mmAq		-4000mmAq		-5000mmAq		-6000mmAq	
		Qs	kw	Qs	kw	Qs	kw	Qs	kw	Qs	kw	Qs	kw
RSV-50	1050	2.13	0.55	1.88	1.08	1.64	1.60	1.39	2.10	1.11	2.59	0.79	3.06
	1150	2.40	0.60	2.15	1.19	1.91	1.75	1.66	2.30	1.38	2.84	1.06	3.36
	1250	2.67	0.66	2.42	1.29	2.18	1.90	1.93	2.50	1.65	3.08	1.33	3.65
	1350	2.93	0.71	2.68	1.39	2.44	2.06	2.19	2.70	1.91	3.33	1.59	3.94
	1450	3.20	0.76	2.95	1.50	2.71	2.21	2.46	2.90	2.18	3.57	1.86	4.23
	1550	3.47	0.81	3.22	1.60	2.98	2.36	2.73	3.10	2.45	3.82	2.13	4.52
	1650	3.74	0.86	3.49	1.70	3.25	2.51	3.00	3.30	2.72	4.07	2.40	4.82
	1750	4.01	0.91	3.76	1.80	3.52	2.66	3.27	3.50	2.99	4.31	2.67	5.11
	1850	4.28	0.97	4.03	1.91	3.79	2.82	3.54	3.70	3.26	4.56	2.94	5.40
1950	4.55	1.02	4.30	2.01	4.06	2.97	3.81	3.90	3.53	4.80	3.21	5.69	

機型 Model	轉速 RPM	Type RSV-65 performance											
		-1000mmAq		-2000mmAq		-3000mmAq		-4000mmAq		-5000mmAq		-6000mmAq	
		Qs	kw	Qs	kw	Qs	kw	Qs	kw	Qs	kw	Qs	kw
RSV-65	1050	2.87	0.75	2.67	1.48	2.42	2.17	2.14	2.84	1.83	3.47	1.46	4.09
	1150	3.23	0.83	3.03	1.62	2.78	2.37	2.50	3.10	2.19	3.80	1.82	4.48
	1250	3.59	0.90	3.39	1.77	3.14	2.58	2.86	3.38	2.55	4.13	2.18	4.87
	1350	3.95	0.97	3.75	1.91	3.50	2.79	3.22	3.65	2.91	4.46	2.54	5.26
	1450	4.31	1.05	4.11	2.04	3.86	3.00	3.58	3.92	3.27	4.79	2.90	5.65
	1550	4.67	1.12	4.47	2.19	4.22	3.21	3.94	4.19	3.63	5.12	3.26	6.04
	1650	5.03	1.19	4.83	2.33	4.58	3.41	4.30	4.46	3.99	5.46	3.62	6.43
	1750	5.39	1.26	5.19	2.47	4.94	3.62	4.66	4.73	4.35	5.79	3.98	6.82
	1850	5.75	1.34	5.55	2.61	5.30	3.83	5.02	5.00	4.71	6.12	4.34	7.21
1950	6.11	1.41	5.91	2.76	5.66	4.04	5.38	5.27	5.07	6.45	4.70	7.60	

機型 Model	轉速 RPM	Type RSV-80 performance											
		-1000mmAq		-2000mmAq		-3000mmAq		-4000mmAq		-5000mmAq		-6000mmAq	
		Qs	kw	Qs	kw	Qs	kw	Qs	kw	Qs	kw	Qs	kw
RSV-80	1000	5.01	1.36	4.53	2.60	4.01	3.73	3.40	4.77	2.73	5.74	1.96	6.63
	1100	5.61	1.49	5.13	2.85	4.61	4.11	4.01	5.25	3.34	6.32	2.56	7.30
	1200	6.21	1.63	5.73	3.11	5.21	4.48	4.61	5.73	3.94	6.89	3.16	7.96
	1300	6.81	1.76	6.33	3.37	5.81	4.85	5.21	6.21	4.54	7.47	3.76	8.62
	1400	7.41	1.90	6.93	3.63	6.41	5.23	5.81	6.69	5.14	8.04	4.37	9.29
	1500	8.01	2.03	7.53	3.89	7.01	5.60	6.41	7.17	5.74	8.61	4.97	9.95
	1600	8.61	2.17	8.13	4.15	7.61	5.97	7.01	7.64	6.34	9.19	5.57	10.61
	1650	8.91	2.24	8.43	4.28	7.91	6.16	7.31	7.88	6.64	9.47	5.87	10.95
	1750	9.51	2.38	9.04	4.54	8.51	6.53	7.91	8.36	7.24	10.04	6.47	11.61
	1850	10.11	2.52	9.64	4.80	9.11	6.90	8.51	8.83	7.84	10.62	7.07	12.28
	1950	10.71	2.65	10.24	5.06	9.71	7.28	9.11	9.31	8.44	11.19	7.67	12.94

機型 Model	轉速 RPM	Type RSV-100 performance											
		-1000mmAq		-2000mmAq		-3000mmAq		-4000mmAq		-5000mmAq		-6000mmAq	
		Qs	kw	Qs	kw	Qs	kw	Qs	kw	Qs	kw	Qs	kw
RSV-100	1000	7.08	1.78	6.45	3.42	5.74	4.90	4.94	6.30	4.04	7.56	3.02	8.79
	1100	7.93	1.97	7.29	3.76	6.59	5.40	5.78	6.93	4.89	8.35	3.86	9.70
	1200	8.77	2.16	8.14	4.10	7.43	5.91	6.63	7.56	5.73	9.13	4.71	10.61
	1300	9.62	2.35	8.98	4.44	8.28	6.41	7.47	8.19	6.58	9.92	5.55	11.53
	1400	10.46	2.52	9.83	4.77	9.12	6.87	8.32	8.81	7.42	10.66	6.40	12.40
	1500	11.31	2.69	10.67	5.10	9.97	7.34	9.16	9.44	8.27	11.41	7.24	13.27
	1600	12.15	2.86	11.52	5.44	10.81	7.81	10.01	10.06	9.11	12.16	8.09	14.15
	1650	12.58	2.95	11.94	5.61	11.24	8.05	10.43	10.37	9.54	12.55	8.51	14.57
	1750	13.42	3.13	12.79	5.96	12.08	8.55	11.28	11.01	10.38	13.32	9.36	15.41
	1850	14.27	3.30	13.63	6.30	12.93	9.04	12.12	11.65	11.23	14.08	10.20	16.24
	1950	15.11	3.48	14.48	6.65	13.77	9.53	12.97	12.28	12.07	14.85	11.05	17.08

RSV性能表

註：入口流量 Qs=m³/min

機型 Model	轉速 RPM	Type RSV-125A performance											
		-1000mmAq		-2000mmAq		-3000mmAq		-4000mmAq		-5000mmAq		-6000mmAq	
		Qs	kw	Qs	kw	Qs	kw	Qs	kw	Qs	kw	Qs	kw
RSV-125A	990	10.39	2.46	9.66	4.72	8.82	6.79	7.84	8.69	6.78	10.46	5.52	12.08
	1050	11.09	2.61	10.36	5.00	9.52	7.20	8.54	9.22	7.47	11.09	6.21	12.82
	1110	11.79	2.76	11.06	5.29	10.22	7.62	9.24	9.75	8.17	11.72	6.91	13.55
	1180	12.61	2.93	11.88	5.62	11.04	8.10	10.06	10.37	8.99	12.47	7.73	14.41
	1250	13.43	3.10	12.70	5.96	11.85	8.58	10.88	10.98	9.81	13.21	8.55	15.26
	1320	14.25	3.28	13.51	6.29	12.67	9.06	11.69	11.60	10.63	13.95	9.36	16.12
	1390	15.06	3.45	14.33	6.63	13.48	9.54	12.51	12.22	11.44	14.69	10.18	16.98
	1470	16.00	3.65	15.26	7.01	14.42	10.09	13.44	12.92	12.38	15.54	11.12	17.96
	1560	17.05	3.88	16.31	7.44	15.47	10.71	14.49	13.71	13.43	16.49	12.17	19.06
	1650	18.10	4.11	17.36	7.87	16.52	11.33	15.55	14.51	14.48	17.44	13.22	20.16
	1750	19.26	4.36	18.53	8.35	17.69	12.02	16.71	15.39	15.64	18.50	14.38	21.38
1850	20.43	4.61	19.70	8.82	18.85	12.70	17.88	16.27	16.81	19.56	15.55	22.60	

機型 Model	轉速 RPM	Type RSV-125 performance											
		-1000mmAq		-2000mmAq		-3000mmAq		-4000mmAq		-5000mmAq		-6000mmAq	
		Qs	kw	Qs	kw	Qs	kw	Qs	kw	Qs	kw	Qs	kw
RSV-125	990	15.07	3.65	14.00	6.95	12.87	9.98	11.66	12.80	10.37	15.46	8.97	18.04
	1050	16.13	3.88	15.05	7.38	13.92	10.60	12.72	13.61	11.42	16.42	10.02	19.15
	1110	17.18	4.10	16.10	7.82	14.98	11.23	13.77	14.42	12.47	17.39	11.07	20.27
	1180	18.41	4.37	17.33	8.32	16.21	11.97	14.99	15.35	13.70	18.52	12.30	21.57
	1250	19.63	4.63	18.55	8.82	17.42	12.69	16.21	16.27	14.92	19.64	13.52	22.86
	1320	20.85	4.89	19.78	9.34	18.65	13.43	17.44	17.21	16.15	20.77	14.74	24.15
	1390	22.08	5.16	21.01	9.84	19.88	14.16	18.67	18.15	17.38	21.89	15.97	25.45
	1470	23.48	5.46	22.40	10.42	21.28	14.99	20.06	19.21	18.77	23.17	17.36	26.92
	1560	25.06	5.80	23.98	11.07	22.85	15.92	21.64	20.40	20.35	24.61	18.95	28.60
	1650	26.63	6.14	25.55	11.71	24.42	16.85	23.21	21.60	21.92	26.04	20.52	30.25
	1750	28.38	6.52	27.31	12.44	26.18	17.89	24.97	22.93	23.67	27.65	22.28	32.10
1850	30.13	6.90	29.05	13.15	27.92	18.92	26.71	24.26	25.42	29.24	24.02	33.93	

機型 Model	轉速 RPM	Type RSV-150 performance											
		-1000mmAq		-2000mmAq		-3000mmAq		-4000mmAq		-5000mmAq		-6000mmAq	
		Qs	kw	Qs	kw	Qs	kw	Qs	kw	Qs	kw	Qs	kw
RSV-150	990	19.53	4.69	18.70	8.95	17.76	12.88	16.70	16.49	15.47	19.85	14.11	22.94
	1050	20.86	4.97	20.03	9.50	19.09	13.66	18.03	17.49	16.80	21.04	15.44	24.33
	1110	22.19	5.25	21.36	10.04	20.42	14.44	19.36	18.49	18.13	22.24	16.77	25.72
	1180	23.74	5.59	22.91	10.67	21.97	15.36	20.91	19.66	19.68	23.65	18.32	27.36
	1250	25.29	5.92	24.46	11.31	23.52	16.27	22.46	20.83	21.23	25.06	19.87	28.99
	1320	26.84	6.26	26.01	11.94	25.07	17.18	24.00	22.00	22.78	26.47	21.41	30.62
	1390	28.39	6.59	27.56	12.58	26.62	18.09	25.55	23.16	24.33	27.87	22.96	32.21
	1470	30.16	6.96	29.33	13.30	28.39	19.13	27.32	24.49	26.10	29.47	24.73	34.06
	1560	32.15	7.38	31.32	14.12	30.38	20.30	29.31	26.00	28.09	31.28	26.72	36.15
	1650	34.14	7.81	33.31	14.94	32.37	21.46	31.30	27.51	30.08	33.06	28.71	38.25
	1750	36.35	8.28	35.52	15.84	34.58	22.77	33.51	29.18	32.29	35.07	30.92	40.57
1850	38.56	8.76	37.73	16.75	36.78	24.07	35.71	30.85	34.50	37.09	33.12	42.90	

機型 Model	轉速 RPM	Type RSV-200A performance											
		-1000mmAq		-2000mmAq		-3000mmAq		-4000mmAq		-5000mmAq		-6000mmAq	
		Qs	kw	Qs	kw	Qs	kw	Qs	kw	Qs	kw	Qs	kw
RSV-200A	990	32.00	7.92	30.86	15.24	29.65	21.95	28.31	28.18	26.89	33.86	25.31	39.26
	1050	34.29	8.41	33.15	16.16	31.94	23.28	30.60	29.89	29.18	35.91	27.60	41.64
	1110	36.58	8.90	35.43	17.10	34.22	24.62	32.88	31.62	31.46	38.02	29.87	44.07
	1180	39.25	9.49	38.10	18.20	36.89	26.19	35.55	33.64	34.13	40.47	32.54	46.91
	1250	41.93	10.07	40.78	19.30	39.57	27.76	38.23	35.65	36.81	42.93	35.22	49.74
	1320	44.60	10.65	43.45	20.40	42.24	29.33	40.90	37.67	39.48	45.38	37.89	52.57
	1390	47.27	11.23	46.12	21.50	44.91	30.90	43.57	39.68	42.15	47.83	40.56	55.36
	1470	50.32	11.90	49.17	22.75	47.96	32.70	46.62	41.99	45.20	50.63	43.61	58.55

機型 Model	轉速 RPM	Type RSV-200 performance											
		-1000mmAq		-2000mmAq		-3000mmAq		-4000mmAq		-5000mmAq		-6000mmAq	
		Qs	kw	Qs	kw	Qs	kw	Qs	kw	Qs	kw	Qs	kw
RSV-200	990	41.57	10.24	40.07	19.64	38.48	28.27	36.73	36.29	34.89	43.60	32.84	50.55
	1050	44.50	10.86	43.00	20.84	41.41	30.00	39.67	38.50	37.82	46.25	35.78	53.61
	1110	47.42	11.51	45.91	22.06	44.33	31.73	42.58	40.73	40.74	48.96	38.68	56.74
	1180	50.82	12.26	49.32	23.47	47.73	33.75	45.99	43.33	44.14	52.12	42.09	60.39
	1250	54.23	13.01	52.72	24.89	51.14	35.78	49.40	45.92	47.55	55.28	45.50	64.04
	1320	57.62	13.76	56.11	26.31	54.53	37.80	52.79	48.52	50.95	58.43	48.90	67.69
	1390	61.00	14.52	59.49	27.73	57.91	39.82	56.17	51.12	54.33	61.59	52.28	71.33
	1470	64.84	15.37	63.34	29.34	61.77	42.13	60.02	54.08	58.18	64.95	56.14	75.41

RSV性能表

註：入口流量 Qs=m³/min

機型 Model	轉速 RPM	Type RSV-250 performance											
		-1000mmAq		-2000mmAq		-3000mmAq		-4000mmAq		-5000mmAq		-6000mmAq	
		Qs	kw	Qs	kw	Qs	kw	Qs	kw	Qs	kw	Qs	kw
RSV-250	990	57.43	13.36	55.39	25.66	53.22	36.96	50.82	47.56	48.30	57.08	45.49	66.37
	1050	61.44	14.18	59.40	27.24	57.23	39.23	54.84	50.49	52.31	60.57	49.52	70.41
	1110	65.43	15.07	63.37	28.86	61.22	41.53	58.82	53.46	56.30	64.22	53.48	74.62
	1180	70.07	16.10	68.03	30.77	65.86	44.21	63.48	56.91	60.95	68.46	58.15	79.53
	1250	74.72	17.12	72.67	32.66	70.52	46.90	68.14	60.37	65.61	72.72	62.80	84.43
	1320	79.34	18.15	77.29	34.57	75.14	49.60	72.76	63.83	70.24	76.98	67.44	89.33
	1390	83.94	19.18	81.89	36.48	79.74	52.29	77.36	67.28	74.84	81.23	72.04	94.25
1470	89.16	20.35	87.13	38.65	84.99	55.36	82.60	71.24	80.09	85.42	77.30	99.86	

機型 Model	轉速 RPM	Type RSV-300A performance											
		-1000mmAq		-2000mmAq		-3000mmAq		-4000mmAq		-5000mmAq		-6000mmAq	
		Qs	kw	Qs	kw	Qs	kw	Qs	kw	Qs	kw	Qs	kw
RSV-300A	990	77.99	18.61	75.23	35.63	72.30	51.24	69.22	65.64	65.77	78.92	61.91	91.25
	1050	83.39	19.74	80.64	37.79	77.68	54.35	74.61	69.63	71.15	83.70	67.30	96.79
	1110	88.76	20.88	85.98	39.95	83.05	57.46	79.95	73.60	76.49	88.50	72.65	102.33
	1180	95.00	22.20	92.24	42.48	89.27	61.09	86.15	78.26	82.69	94.10	78.84	108.80
	1250	101.24	23.52	98.47	45.01	95.47	64.72	92.35	82.90	88.89	99.70	85.04	115.28
	1320	107.43	24.84	104.66	47.53	101.67	68.35	98.55	87.55	95.09	105.30	91.24	121.76
	1390	113.58	26.17	110.82	50.06	107.86	71.98	104.70	92.20	101.28	110.89	97.43	128.23
1470	120.56	27.68	117.83	52.95	114.85	76.13	111.65	97.51	108.20	117.29	104.36	135.63	

機型 Model	轉速 RPM	Type RSV-300 performance											
		-1000mmAq		-2000mmAq		-3000mmAq		-4000mmAq		-5000mmAq		-6000mmAq	
		Qs	kw	Qs	kw	Qs	kw	Qs	kw	Qs	kw	Qs	kw
RSV-300	800	98.94	22.60	95.93	40.56	92.85	58.38	89.21	76.69	85.17	94.00	80.67	112.10
	900	112.33	25.42	109.32	45.62	106.24	65.65	102.60	86.22	98.56	105.50	94.06	126.08
	1000	125.72	28.24	122.71	50.69	119.63	72.93	115.99	95.82	111.95	116.70	107.45	140.12
	1100	139.05	31.06	136.10	55.76	133.02	80.22	129.38	105.36	125.34	128.37	120.84	153.87
	1200	152.44	33.89	149.49	60.83	146.41	87.51	142.76	114.96	138.73	140.04	134.23	168.08
	1300	165.82	36.71	162.88	65.89	159.80	94.79	156.15	124.53	152.12	151.70	147.62	182.08
	1400	179.20	39.53	176.27	70.96	173.19	102.08	169.54	134.11	165.51	163.36	161.01	196.07

機型 Model	轉速 RPM	Type RSV-350 performance											
		-1000mmAq		-2000mmAq		-3000mmAq		-4000mmAq		-5000mmAq		-6000mmAq	
		Qs	kw	Qs	kw	Qs	kw	Qs	kw	Qs	kw	Qs	kw
RSV-350	800	155.92	35.31	151.40	63.30	146.82	91.17	141.42	118.96	135.46	145.75	128.84	174.47
	900	176.95	39.74	172.44	73.20	167.86	102.05	162.46	133.82	156.50	164.10	149.88	196.35
	1000	197.99	44.17	193.48	79.10	188.90	114.04	183.50	148.76	177.54	182.44	170.92	218.28
	1100	218.94	48.60	214.52	87.00	209.94	125.49	204.54	163.66	198.58	200.78	191.96	239.98
	1200	239.98	53.00	235.56	94.90	230.98	136.95	225.57	178.60	219.61	219.14	213.00	262.05
	1300	261.00	57.40	256.60	102.80	252.02	148.39	246.61	193.47	240.65	237.44	234.04	283.95
	1400	282.03	61.80	277.64	110.70	273.06	159.85	267.65	208.40	261.69	255.77	255.08	305.84

機型 Model	轉速 RPM	Type RSV-400 performance											
		-1000mmAq		-2000mmAq		-3000mmAq		-4000mmAq		-5000mmAq		-6000mmAq	
		Qs	kw	Qs	kw	Qs	kw	Qs	kw	Qs	kw	Qs	kw
RSV-400	800	181.61	41.03	176.34	73.65	171.01	106.00	164.73	139.25	157.82	169.51	150.17	203.54
	900	206.13	46.16	200.86	86.09	195.52	119.22	189.24	156.58	182.34	190.72	174.69	228.95
	1000	230.65	51.28	225.38	92.07	220.04	132.46	213.76	174.03	206.86	211.94	199.20	254.48
	1100	255.05	56.41	249.89	101.27	244.56	145.71	238.28	191.37	231.37	233.15	223.72	279.46
	1200	279.57	61.55	274.41	110.49	269.07	158.95	262.80	208.81	255.89	254.37	248.24	305.31

RSV性能曲線圖

RSV-40

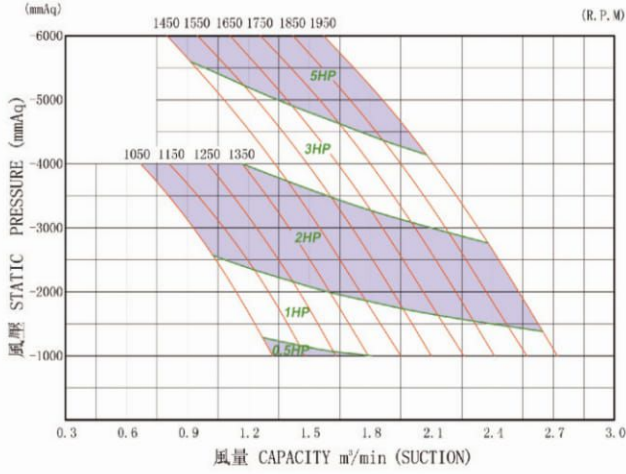

RSV-50

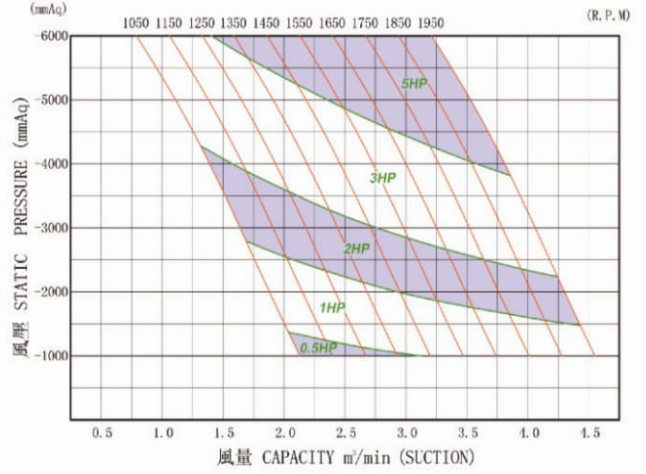

RSV-65

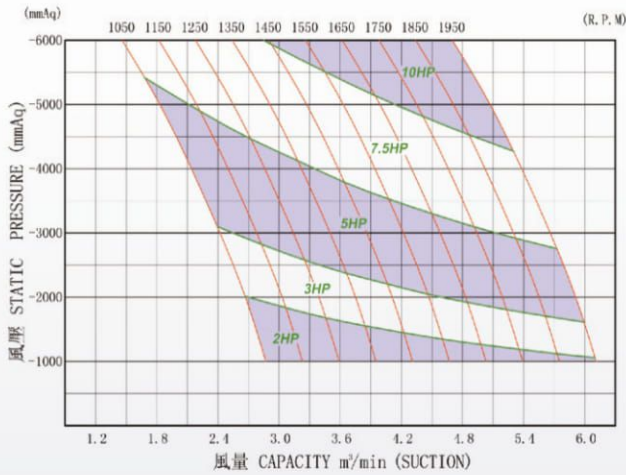

RSV-80

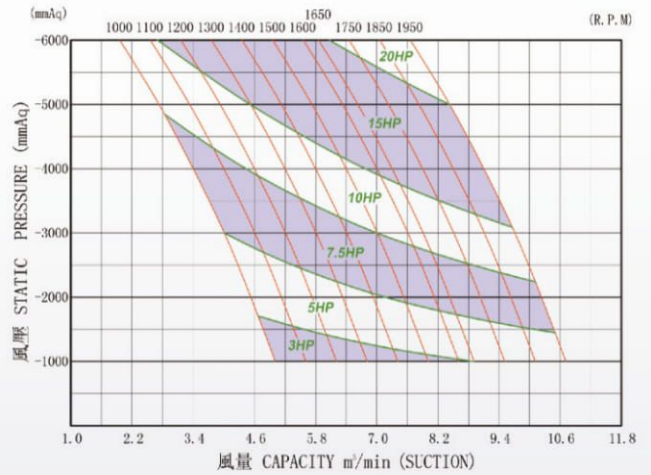

RSV-100

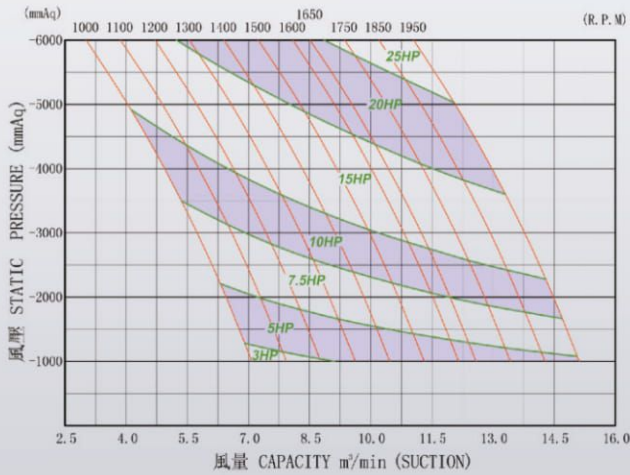

RSV-125A

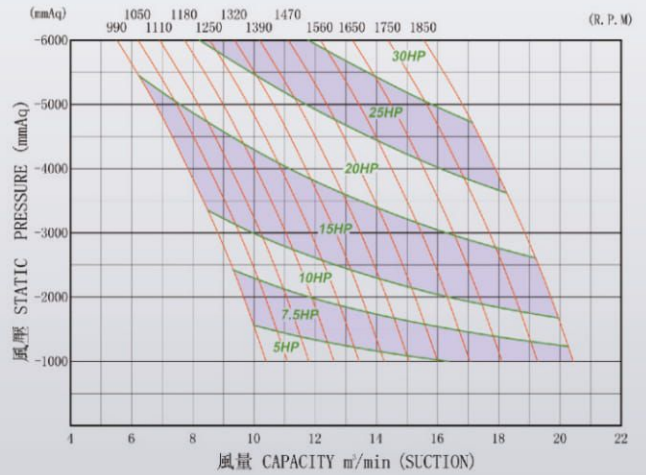

RSV性能曲線圖

RSV-125

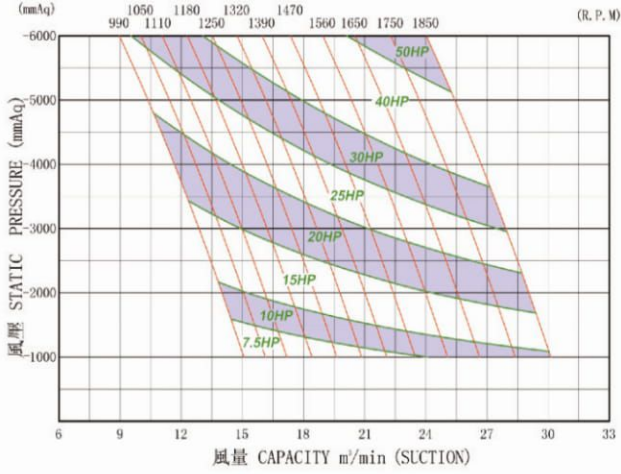

RSV-150

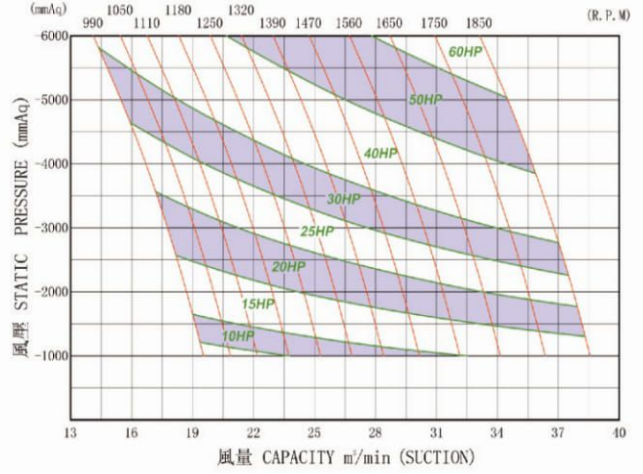

RSV-200A

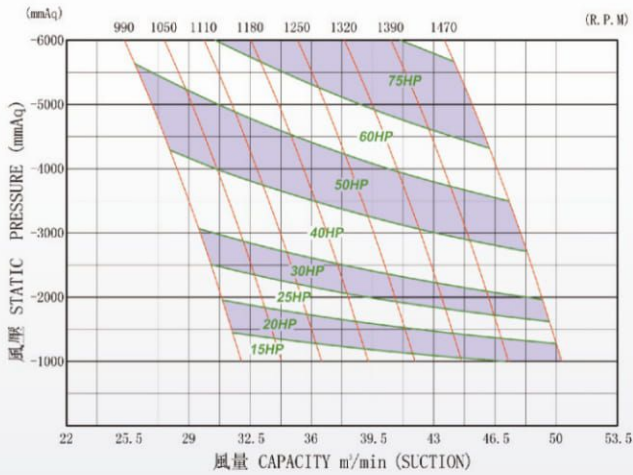

RSV-200

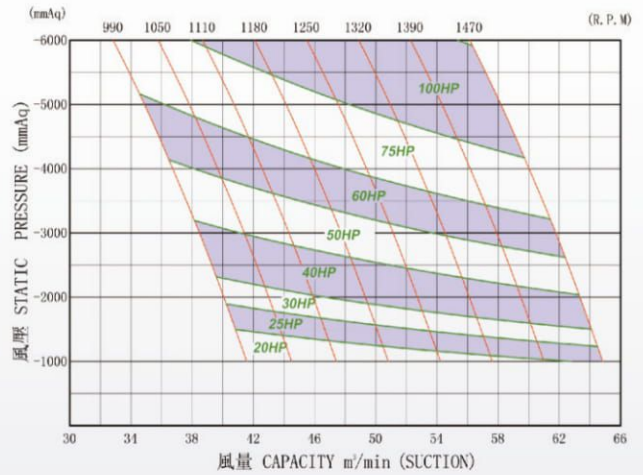

RSV-250

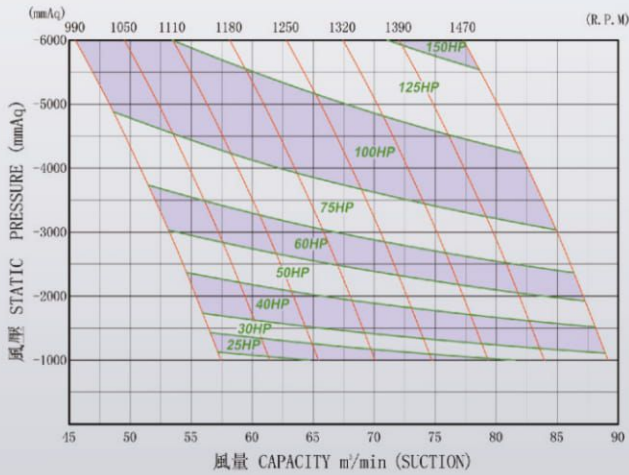

RSV-300A

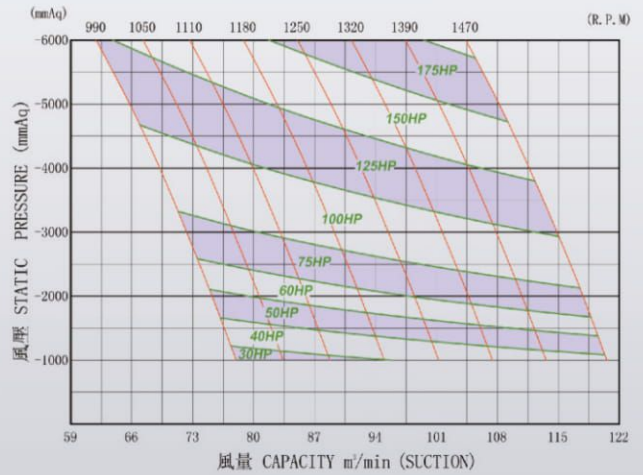

RSV性能曲線圖

RSV-300

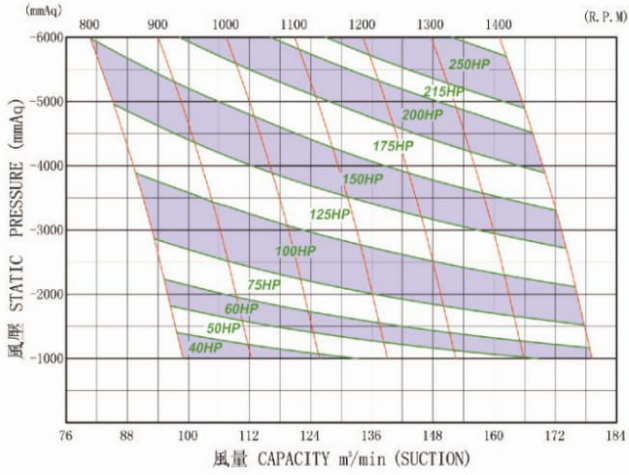

RSV-350

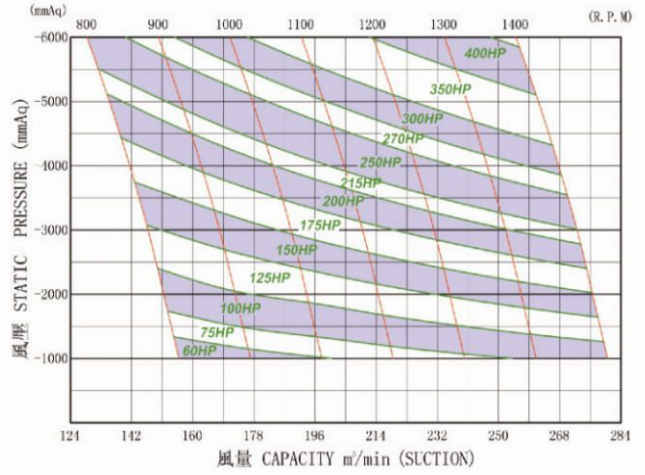

RSV-400

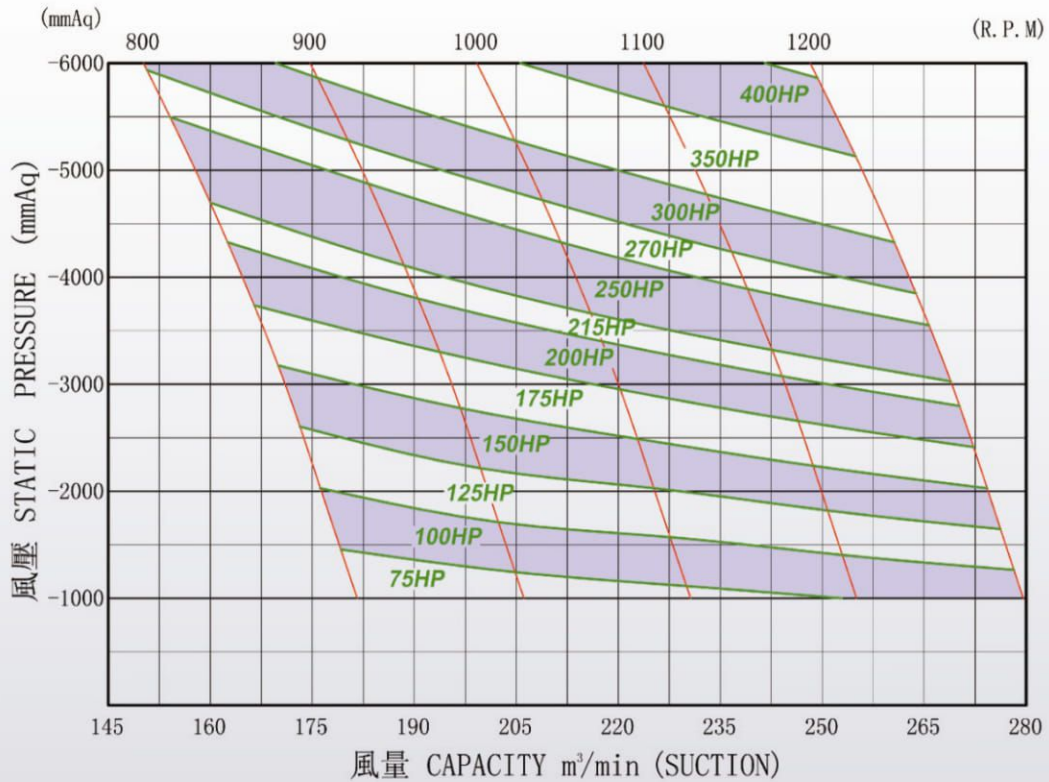

RSW性能表

註：入口流量 $Q_s = m^3/min$

機型 Model	口徑Bore Inch (mm)	轉速 RPM	8000mmAq		9000mmAq		10000mmAq		冷卻水量 Cooling Water Volume(L/min)
			Q_s	kw	Q_s	kw	Q_s	kw	
RSW-40	1-1/2 (40)	1450	0.94	3.21	0.81	3.61	0.67	4.01	4
		1550	1.07	3.43	0.94	3.86	0.81	4.28	
		1650	1.21	3.65	1.07	4.10	0.94	4.56	
		1750	1.34	3.87	1.21	4.35	1.07	4.84	
		1850	1.47	4.09	1.34	4.60	1.20	5.11	
		1950	1.60	4.31	1.47	4.85	1.33	5.39	
RSW-50	2 (50)	1450	1.84	5.34	1.73	6.01	1.66	6.68	4
		1550	2.10	5.71	1.99	6.43	1.92	7.14	
		1650	2.36	6.08	2.25	6.84	2.18	7.60	
		1750	2.62	6.45	2.51	7.26	2.44	8.06	
		1850	2.87	6.82	2.77	7.67	2.70	8.52	
RSW-65	2-1/2 (65)	1950	3.13	7.19	3.03	8.09	2.95	8.98	6
		1350	2.82	6.47	2.69	7.28	2.58	8.09	
		1450	3.16	6.95	3.03	7.82	2.92	8.68	
		1550	3.50	7.43	3.37	8.35	3.26	9.28	
		1650	3.83	7.91	3.71	8.89	3.59	9.88	
RSW-80	3 (80)	1300	4.13	11.06	3.78	12.44	3.44	13.82	8
		1400	4.73	11.91	4.38	13.39	4.04	14.88	
		1500	5.33	12.76	4.98	14.35	4.64	15.95	
		1600	5.93	13.61	5.57	15.31	5.24	17.01	
		1650	6.23	14.03	5.87	15.79	5.54	17.54	
		1750	6.82	14.88	6.47	16.74	6.13	18.60	
		1850	7.42	15.73	7.07	17.70	6.73	19.67	
RSW-100	4 (100)	1950	8.02	16.58	7.67	18.66	7.33	20.73	10
		1200	6.69	14.29	6.43	16.07	6.20	17.86	
		1300	7.53	15.48	7.27	17.41	7.04	19.35	
		1400	8.37	16.67	8.11	18.75	7.88	20.84	
		1500	9.21	17.86	8.95	20.09	8.72	22.32	
RSW-125A	5 (125)	1180	9.15	20.59	8.52	23.16	7.78	25.73	12
		1250	10.01	21.81	9.38	24.53	8.64	27.26	
		1320	10.87	23.03	10.24	25.91	9.50	28.78	
		1390	11.73	24.25	11.10	27.28	10.36	30.31	
		1470	12.71	25.64	12.08	28.85	11.34	32.06	
		1560	13.82	27.21	13.19	30.62	12.45	34.02	
		1650	14.92	28.78	14.29	32.38	13.56	35.98	
		1750	16.15	30.53	15.52	34.35	14.78	38.16	
RSW-125	5 (125)	1850	17.38	32.27	16.75	36.31	16.01	40.34	12
		1180	14.35	30.09	13.55	33.85	12.61	37.61	
		1250	15.61	31.87	14.80	35.86	13.86	39.84	
		1320	16.87	33.66	16.06	37.86	15.12	42.07	
		1390	18.12	35.44	17.32	39.87	16.38	44.30	
		1470	19.56	37.48	18.75	42.17	17.81	46.85	
		1560	21.18	39.78	20.37	44.75	19.43	49.72	
		1650	22.79	42.07	21.98	47.33	21.04	52.59	
		1750	24.59	44.62	23.78	50.20	22.84	55.77	
RSW-150	6 (150)	1850	26.38	47.17	25.57	53.07	24.64	58.96	15
		1180	18.97	38.80	17.61	43.65	16.42	48.49	
		1250	20.59	41.10	19.23	46.23	18.04	51.37	
		1320	22.21	43.40	20.85	48.82	19.66	54.25	
		1390	23.83	45.70	22.47	51.41	21.28	57.12	
RSW-200A	8 (200)	1470	25.69	48.33	24.32	54.37	23.13	60.41	20
		990	26.58	52.26	25.43	58.80	24.03	65.33	
		1050	28.81	55.43	27.66	62.36	26.26	69.29	
		1110	31.04	58.60	29.89	65.92	28.49	73.25	
		1180	33.64	62.29	32.49	70.08	31.09	77.87	
		1250	36.24	65.99	35.09	74.24	33.70	82.48	
RSW-200	8 (200)	1320	38.84	69.68	37.70	78.39	36.30	87.10	25
		1390	41.44	73.38	40.30	82.55	38.90	91.72	
		990	34.38	67.19	32.65	75.59	30.84	83.99	
		1050	37.25	71.27	35.51	80.18	33.71	89.08	
		1110	40.12	75.34	38.38	84.76	36.58	94.17	
		1180	43.46	80.09	41.73	90.10	39.92	100.11	
		1250	46.81	84.84	45.07	95.45	43.27	106.05	
RSW-250	10 (250)	1320	50.15	89.59	48.42	100.79	46.61	111.99	25
		1390	53.50	94.34	51.76	106.14	49.96	117.93	
		1050	51.94	95.02	50.36	106.90	48.32	118.78	
		1110	55.76	100.45	54.18	113.01	52.15	125.57	
		1180	60.22	106.79	58.64	120.14	56.61	133.48	
		1250	64.68	113.12	63.10	127.26	61.07	141.40	
		1320	69.14	119.46	67.56	134.39	65.53	149.32	
RSW-300	12 (300)	1390	73.60	125.79	72.02	141.52	69.99	157.24	30
		1480	79.33	133.94	77.76	150.68	75.72	167.42	
		600	55.28	111.50	52.93	125.44	50.60	139.38	
		700	68.65	130.08	66.30	146.34	63.97	162.60	
		800	82.02	148.67	79.67	167.25	77.34	185.83	
		900	95.39	167.25	93.04	188.16	90.70	209.06	
		1000	108.75	185.83	106.41	209.06	104.07	232.29	
		1100	122.12	204.42	119.77	229.97	117.44	255.52	
		1200	135.49	223.00	133.14	250.88	130.81	278.75	
1300	148.86	241.58	146.51	271.78	144.18	301.98			
1400	162.23	260.17	159.88	292.69	157.55	325.21			

TRS性能表

註：入口流量 $Q_s = m^3/min$

機型 Model	轉速 RPM	Type TRS-200A performance (RSW-200A + RSW-200A)																				冷卻水量 (L/min)			
		1000mmAq		1100mmAq		1200mmAq		1300mmAq		1400mmAq		1500mmAq		1600mmAq		1700mmAq		1800mmAq		1900mmAq		2000mmAq		Air	Blower
		Qs	kw	Qs	kw	Qs	kw	Qs	kw	Qs	kw	Qs	kw	Qs	kw	Qs	kw	Qs	kw	Qs	kw	Qs	kw		
TRS-200A	990	28.10	65.33	27.76	71.86	27.41	78.39	27.24	84.93	26.73	91.46	26.37	97.99	26.00	104.52	25.72	111.06	25.43	117.59	24.73	124.12	24.03	130.66	400	40
	1050	30.23	69.29	29.89	76.22	29.55	83.14	29.38	90.07	28.87	97.00	28.56	103.93	28.24	110.86	27.95	117.79	27.66	124.72	26.96	131.65	26.26	138.57		
	1110	32.37	73.25	32.03	80.57	31.69	87.90	31.52	95.22	31.01	102.54	30.67	109.87	30.32	117.19	30.11	124.52	29.89	131.84	29.19	139.17	28.49	146.49		
	1180	34.90	77.87	34.51	85.65	34.12	93.44	34.02	101.23	33.53	109.01	33.18	116.80	32.83	124.58	32.66	132.37	32.49	140.16	31.79	147.94	31.09	155.73		
	1250	37.33	82.48	36.99	90.73	36.64	98.98	36.52	107.23	36.06	115.48	35.74	123.73	35.41	131.98	35.25	140.22	35.09	148.47	34.40	156.72	33.70	164.97		
	1320	39.85	87.10	39.51	95.81	39.17	104.52	39.00	113.23	38.49	121.95	38.15	130.66	37.80	139.37	37.75	148.08	37.70	156.79	37.00	165.50	36.30	174.21		
	1390	42.28	91.72	41.94	100.90	41.60	110.07	41.48	119.24	41.02	128.41	40.67	137.58	40.31	146.76	40.30	155.93	40.30	165.10	39.60	174.27	38.90	183.45		

機型 Model	轉速 RPM	Type TRS-200 performance (RSW-200 + RSW-200A)																				冷卻水量 (L/min)			
		1000mmAq		1100mmAq		1200mmAq		1300mmAq		1400mmAq		1500mmAq		1600mmAq		1700mmAq		1800mmAq		1900mmAq		2000mmAq		Air	Blower
		Qs	kw	Qs	kw	Qs	kw	Qs	kw	Qs	kw	Qs	kw	Qs	kw	Qs	kw	Qs	kw	Qs	kw	Qs	kw		
TRS-200	990	36.10	74.66	35.65	82.13	35.20	89.59	34.80	97.06	34.40	104.52	33.70	109.95	33.01	115.38	32.83	124.89	32.65	134.39	31.75	141.85	30.84	149.32	400	45
	1050	38.90	79.19	38.45	87.10	38.00	95.02	37.60	102.94	37.20	110.86	36.48	116.74	35.76	122.62	35.64	132.58	35.51	142.53	34.61	150.45	33.71	158.37		
	1110	41.60	83.71	41.15	92.08	40.70	100.45	40.25	108.82	39.80	117.19	39.16	123.53	38.51	129.86	38.45	140.27	38.38	150.68	37.48	159.05	36.58	167.42		
	1180	44.80	88.99	44.35	97.89	43.90	106.79	43.50	115.69	43.10	124.58	42.41	131.11	41.72	137.63	41.73	148.91	41.73	160.18	40.83	169.08	39.92	177.98		
	1250	48.00	94.27	47.55	103.70	47.10	113.12	46.70	122.55	46.30	131.98	45.62	139.03	44.94	146.08	45.00	157.88	45.07	169.68	44.17	179.11	43.27	188.54		
	1320	51.20	99.55	50.75	109.50	50.30	119.46	49.90	129.41	49.50	139.37	48.82	146.95	48.15	154.52	48.28	166.85	48.42	179.18	47.52	189.14	46.61	199.09		
	1390	54.40	104.83	54.00	115.31	53.60	125.79	53.15	136.27	52.70	146.76	52.03	154.86	51.36	162.97	51.56	175.83	51.76	188.69	50.86	199.17	49.96	209.65		

機型 Model	轉速 RPM	Type TRS-250 performance (RSW-250 + RSW-200)																				冷卻水量 (L/min)			
		1000mmAq		1100mmAq		1200mmAq		1300mmAq		1400mmAq		1500mmAq		1600mmAq		1700mmAq		1800mmAq		1900mmAq		2000mmAq		Air	Blower
		Qs	kw	Qs	kw	Qs	kw	Qs	kw	Qs	kw	Qs	kw	Qs	kw	Qs	kw	Qs	kw	Qs	kw	Qs	kw		
TRS-250	990	49.60	97.99	49.15	107.79	48.70	117.59	48.20	127.39	47.70	137.19	47.18	146.99	46.67	156.79	46.14	166.59	45.60	176.39	45.05	186.18	44.50	195.98	400	50
	1050	53.30	103.93	52.80	114.32	52.30	124.72	51.85	135.11	51.40	145.50	50.89	155.90	50.38	166.29	49.86	176.68	49.35	187.08	48.84	197.47	48.32	207.86		
	1110	57.00	109.87	56.50	120.86	56.00	131.84	55.50	142.83	55.00	153.82	54.54	164.80	54.09	175.79	53.59	186.78	53.10	197.77	52.62	208.75	52.15	219.74		
	1180	61.30	116.80	60.80	128.48	60.30	140.16	59.80	151.84	59.30	163.52	58.86	175.20	58.41	186.88	57.94	198.56	57.47	210.24	57.04	221.92	56.61	233.60		
	1250	65.50	123.73	65.00	136.10	64.50	148.47	64.05	160.85	63.60	173.22	63.17	185.59	62.74	197.96	62.29	210.34	61.84	222.71	61.45	235.08	61.07	247.45		
	1320	69.80	130.66	69.30	143.72	68.80	156.79	68.35	169.85	67.90	182.92	67.48	195.98	67.07	209.05	66.64	222.11	66.21	235.18	65.87	248.25	65.53	261.31		
	1390	74.10	137.58	73.60	151.34	73.10	165.10	72.55	178.86	72.00	192.62	71.70	206.38	71.39	220.14	70.99	233.89	70.58	247.65	70.28	261.41	69.99	275.17		

機型 Model	轉速 RPM	Type TRS-300 performance (RSW-300 + RSW-300)																				冷卻水量 (L/min)			
		1000mmAq		1100mmAq		1200mmAq		1300mmAq		1400mmAq		1500mmAq		1600mmAq		1700mmAq		1800mmAq		1900mmAq		2000mmAq		Air	Blower
		Qs	kw	Qs	kw	Qs	kw	Qs	kw	Qs	kw	Qs	kw	Qs	kw	Qs	kw	Qs	kw	Qs	kw	Qs	kw		
TRS-300	700	73.90	169.83	72.90	184.60	71.90	199.37	71.05	215.98	70.20	232.60	69.42	246.38	68.65	260.17	67.47	276.43	66.30	292.69	65.13	308.95	63.97	325.21	500	55
	800	87.30	194.09	86.30	210.97	85.30	227.85	84.45	246.84	83.60	265.82	82.81	281.58	82.02	297.33	80.84	315.92	79.67	334.50	78.50	353.08	77.34	371.67		
	900	100.80	218.35	99.80	237.34	98.80	256.33	97.95	277.69	97.10	299.05	96.24	316.78	95.39	334.50	94.21	355.41	93.04	376.31	91.87	397.22	90.70	418.13		
	1000	114.10	242.62	113.10	263.71	112.10	284.81	111.25	308.54	110.40	332.28	109.58	351.97	108.75	371.67	107.58	394.90	106.41	418.13	105.24	441.36	104.07	464.58		
	1100	127.60	266.88	126.60	290.08	125.60	313.29	124.75	339.40	123.90	365.51	123.01	387.17	122.12	408.83	120.95	434.39	119.77	459.94	118.61	485.49	117.44	511.04		
	1200	141.00	291.14	140.00	316.46	139.00	341.77	138.15	370.25	137.30	398.73	136.40	422.37	135.49	446.00	134.32	473.88	133.14	501.75	131.98	529.63	130.81	557.50		
	1300	154.60	315.40	153.60	342.83	152.60	370.25	151.75	401.11	150.90	431.96	149.88	457.57	148.86	483.17	147.69	513.37	146.51	543.56	145.35	573.76	144.18	603.96		
	1400	166.49	339.66	165.42	369.20	164.34	398.73	163.42	431.96	162.51	465.19	162.37	492.76	162.23	520.33	161.05	552.86	159.88	585.38	158.71	617.90	157.55	650.42		

週邊零件尺寸圖

入口消音器 Suction Silencer

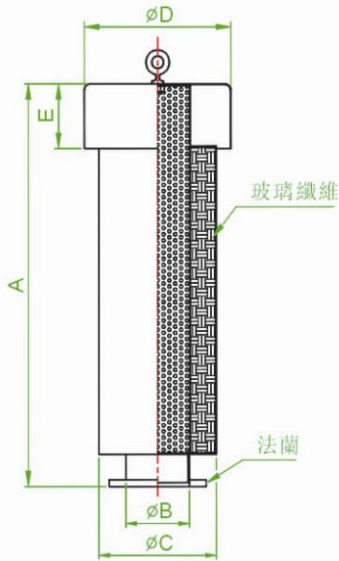

TYPE	A	ϕB	ϕC	ϕD	E	法蘭	適合機型
SS32	112	32	26	156	36	1" PF	RSS-32
SS40	400	60	109	170	70	JIS 2" 5K	RSS-40
SS50	566	60	140	217	80	JIS 2" 10K	RSS-50
SS65	566	76	165	217	80	JIS 2½" 10K	RSS-65
SS80	835	89	216	313	150	JIS 3" 10K	RSS-80
SS100	835	114	240	313	150	JIS 4" 10K	RSS-100
SS125	1321	140	280	395	185	JIS 5" 10K	RSS-125 ; RSS-125A
SS150	1321	165	300	395	185	JIS 6" 10K	RSS-150
SS200	1508	216	400	496	280	JIS 8" 10K	RSS-200 ; RSS-200A
SS250	1715	267	400	572	280	JIS 10" 10K	RSS-250
SS300A	1857	319	500	611	375	JIS 12" 10K	RSS-300A
SS300	1967	319	500	611	375	JIS 12" 10K	RSS-300
SS350	2237	356	550	676	425	JIS 14" 10K	RSS-350
SS400	2533	406	600	720	470	JIS 16" 10K	RSS-400

出口消音器 Discharge Silencer

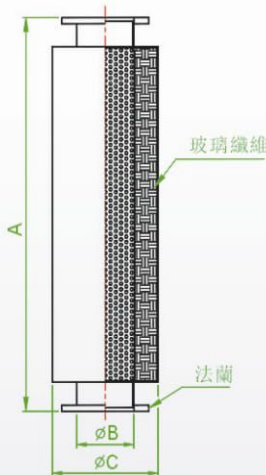

TYPE	A	ϕB	ϕC	法蘭	適合機型
DS50	589	60	140	JIS 2" 10K	RSS-40 ; RSS-50
DS65	589	76	165	JIS 2½" 10K	RSS-65
DS80	789	89	216	JIS 3" 10K	RSS-80
DS100	789	114	240	JIS 4" 10K	RSS-100
DS125	1260	140	280	JIS 5" 10K	RSS-125 ; 125A
DS150	1260	165	300	JIS 6" 10K	RSS-150
DS200	1640	216	400	JIS 8" 10K	RSS-200 ; 200A
DS250	1760	267	400	JIS 10" 10K	RSS-250
DS300A	1750	319	500	JIS 12" 10K	RSS-300A
DS300	1850	319	500	JIS 12" 10K	RSS-300
DS350	2500	356	550	JIS 14" 10K	RSS-350
DS400	2700	406	600	JIS 16" 10K	RSS-400

真空過濾桶(RSV) Vacuum Filter Tank (for RSV)

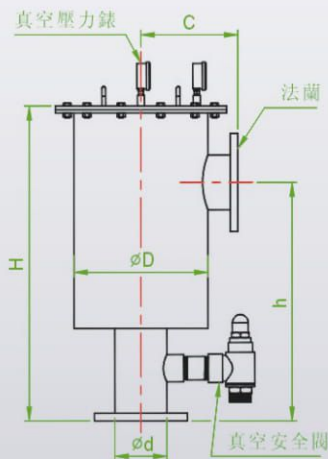

TYPE	H	h	C	ϕD	ϕd	法蘭	適合機型
FT40	657	459	202	244	60	JIS 2" 5K	RSV-40
FT50	657	459	202	244	60	JIS 2" 10K	RSV-50
FT65	657	459	202	244	76	JIS 2½" 10K	RSV-65
FT80	877	613	202	244	89	JIS 3" 10K	RSV-80
FT100	877	613	202	244	114	JIS 4" 10K	RSV-100
FT125	805	610	260	360	140	JIS 5" 10K	RSV-125 ; RSV-125A
FT150	925	690	260	360	165	JIS 6" 10K	RSV-150
FT200	1075	770	310	470	216	JIS 8" 10K	RSV-200 ; RSV-200A
FT250	1200	900	310	470	267	JIS 10" 10K	RSV-250
FT300	1350	1000	405	600	319	JIS 12" 10K	RSV-300 ; RSV-300A
FT350	1550	1150	455	700	356	JIS 14" 10K	RSV-350
FT400	1750	1250	455	700	406	JIS 16" 10K	RSV-400

週邊零件尺寸圖

真空安全閥 Vacuum Relief Valve

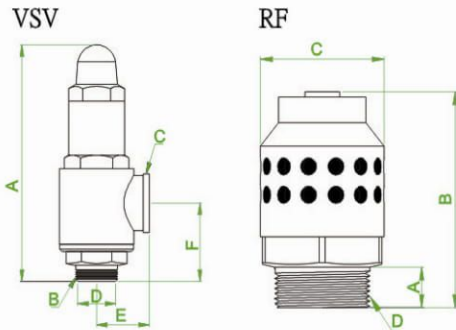

TYPE	A	B	C	D	E	F	適合機型
VSV 1 1/4"	210	1 1/4"	1 1/4"	1 1/4"	51	70	RSV-40,50,65,80
VSV 2"	255	2"	2"	2"	67	89	RSV-100,125A,125,150,200A,200,250

TYPE	A	B	C	D	適合機型
RF 4"	35	168	128	4"	RSV-300A,300,350,400

三通管 "T"-Joint

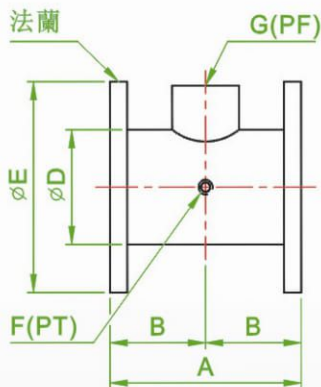

TYPE	A	B	φD	φE	G	F	法蘭	適合機型
HJ50	150	75	60	155	1 1/4"	1/4"	JIS 2" 10K	RSS-40 ; RSS-50
HJ65	150	75	76	175	1 1/4"	1/4"	JIS 2 1/2" 10K	RSS-65
HJ80	180	90	89	185	1 1/4"	1/4"	JIS 3" 10K	RSS-80
HJ100	180	90	114	210	2"	1/4"	JIS 4" 10K	RSS-100
HJ125	250	125	140	250	2"	1/4"	JIS 5" 10K	RSS-125 ; RSS-125A
HJ150	250	125	165	280	2"	1/4"	JIS 6" 10K	RSS-150
HJ200	250	125	216	330	3"	1/4"	JIS 8" 10K	RSS-200 ; RSS-200A
HJ250	250	125	267	400	3"	1/4"	JIS 10" 10K	RSS-250
HJ300	300	150	319	445	3"	1/4"	JIS 12" 10K	RSS-300 ; RSS-300A
HJ350	350	175	356	490	DN150	1/4"	JIS 14" 10K	RSS-350
HJ400	350	175	406	560	DN150	1/4"	JIS 16" 10K	RSS-400

安全閥 Relief Valve

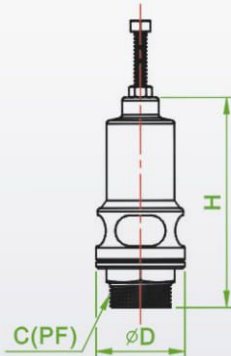

TYPE	H	φD	φC	適合機型
PP 1/2"	182	72	1 1/2"	RSS-32
PP 1 1/4"	182	72	1 1/4"	RSS-40,50,65,80
PP 2"	192	85	2"	RSS-100,125A,125,150
PP 3"	231	115	3"	RSS-200A,200,250,300A,300
SD 150	292	225	DN150	RSS-350,400

逆止閥 Check Valve

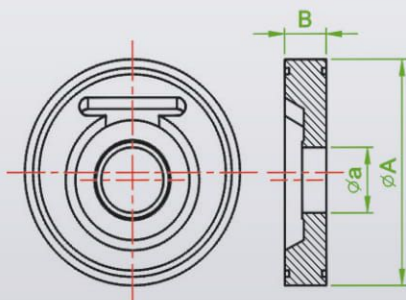

TYPE	φA	φa	B
RSS-40 ; RSS-50	101	26	20
RSS-65	124.5	36	24
RSS-80	133	45	24
RSS-100	157	65	22
RSS-125 ; RSS-125A	187	88	24
RSS-150	220	110	26
RSS-200 ; RSS-200A	269	138	27
RSS-250	330	186	28
RSS-300 ; RSS-300A	380	212	32
RSS-350	428	260	35
RSS-400	482	290	40

防震墊 Vibration Isolator



φ50mm*75mm

適用機種：
RSS-40,50,65,80,100



適用機種：
RSS系列機型

隔音罩



1. 隔音罩之材質為單層SS41鐵板組成，內側襯以玻璃纖維，再貼附吸音棉，確保良好的隔音效果。
2. 隔音罩可降噪音最高為15dB~20dB。
3. 隔音罩進氣孔之風扇皆為排出，以增加空氣代謝。